



MAKSAN®
Endüstriyel Mutfak Ekipmanları

"Profesyonellerin Tercihii"
"The Choice of Professionals"

www.maksanmutfak.com.tr

2021-2022

ÜRÜN KATALOĞU / PRODUCT CATALOG

01

6-37

Washing

Bulaşık Yıkama, Bardak Yıkama ve Sebze Yıkama Makineleri ve Aksesuarları

Dishwasher, Glasswasher, Vegetable Washer Machines and Accessories



GW-535 ECO	8-9
GW-640 ECO	10-11
DW-500 ECO	12-13
DW-1000 ECO	14-15
GW-535	16-17
GW 640	18-19
DW-500	20-21
DW-1000	22-23
DW-2000	24-25
DW-3000	26-27
DW-4500	28-29
DW-6000	30-31
BS-350	32-33
BS-400	32-33
BS-500	32-33
SBY-300	34-35
SBY-600	34-35
SGT-01	36-37
SCT-01	36-37

02

38-65

MKF Patisserie

Konveksiyonlu Patisseri Fırını
Convection Bakery Oven



MKF-3	40-41
MKF-4	42-43
MKF-4P	44-45
MKF-6	46-47
MKF-10	48-49
MKF-4P DIGI	50-51
MKF-6 DIGI	52-53
MKF-10 DIGI	54-55
MKF-6G	56-57
MKF-10G	58-59
MKDF-10	60-61
MD-08	62-63
FT-02 - FT-03 - FT-04 - FT-05	64-65
TR-02 - TR-03	64-65
TK-01 - TK-02 - TK-03	64-65

03 66-77

MKF

Gastronomy

Konveksiyonlu Gastronomi Fırını
Convection Gastronomy Oven



MKF-20E	68-69
MKF-20G	70-71
MKF-40E	72-73
MKF-40G	74-75
FT-01	76-77
ST-01	76-77
ST-02	76-77
TR-01	76-77
TS-01	76-77
TS-02	76-77

04 78-89

Pizza

Ovens



PO-401 - PO-401T	80
PO-402 - PO-402T	81
PO-501 - PO-501T	82
PO-502 - PO-502T	83
PO-601 - PO-601T	84
PO-602 - PO-602T	85
PO-901 - PO-901T	86
PO-902 - PO-902T	87
FT-04	88
FT-05	88
FT-06	89
FT-09	89



MAKSAN®

Endüstriyel Mutfak Ekipmanları

MAKSAN MUTFAK Gaziemir İzmir'de, 5850 m² kapalı alana kurulu modern fabrikasında endüstriyel tip yıkama makineleri, pizza fırınları ve konveksiyonlu fırınlar üretmektedir. Uzmanlık ve tecrübe sahibi personeli sayesinde MAKSAN, üretimini gerçekleştirdiği ürün gruplarında her türlü ihtiyaca cevap verebilecek kabiliyete sahiptir. Üretim denildiğinde akla gelen temel bileşenlerden, arge, tasarım, planlama, üretim ve kalite departmanları sayesinde sektörde sürekli kendini yenileyebilecek bir alt yapıya da sahiptir. Teknik donanımları ve makine parkuru sayesinde MAKSAN ürünlerinin tamamını kendi fabrikasında üretip, kullanıcılara tüm testleri yapılmış, uluslararası güvenlik standartlarına uygun ürünler ulaştırmaktadır.

Saygılarımızla

MAKSAN produces industrial type washing machines, pizza ovens, and convection ovens in Gaziemir, Izmir at the modern factory which has a 5850 m² enclosed area. MAKSAN has the capability to respond to every need of those product groups through expert and experienced personnel. MAKSAN also has an infrastructure to constantly innovate itself thanks to fundamental components of its production such as R&D, design, planning, production, and quality departments. Every product that MAKSAN supplies are produced at its own factory which is delivered to users as all tests are done and conforming to international safety standards.

Best Regards



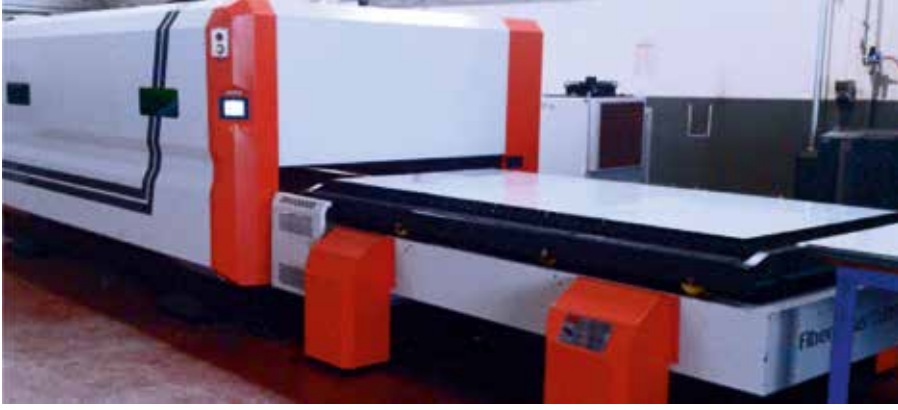

GW-DW

Bulaşık Yıkama,
Bardak Yıkama Makineleri
Dishwashers & Glasswashers



GW-535 ECO

GW-640 ECO

DW-500 ECO

DW-1000 ECO

GW-535

GW-640

DW-500

DW-1000

DW-2000

DW-3000

DW-4500

DW-6000



MAKSAN®



GW-535 ECO

1620 €

Bardak Yıkama Makinesi
Glasswasher



500 bardak/saat
yıkama kapasitesi
35 x 35 cm sepet

500 glass/hour
washing capacity
35 x 35 cm basket



Uluslararası standartlarda güvenlik uygunluğu
Safety conformation to international standarts



Otomatik parlatıcı pompası
Automatic rinse aid system



Kuvvetlendirilmiş plastik bileşenler
Reinforced plastic components



Dayanıklı kapak sistemi
Durable door arm system



Özel üretim parçalar
Special manufactured components

Genel Özellikler

- Paslanmaz çelik gövde ve şase
- Yüksek kalitede paslanmaz çelik ısıtıcılar
- Aynı anda devrede olmayan ısıtma sistemi ile enerji tasarrufu
- Çift cidarlı kapak
- Dönen alt ve üst yıkama kolları
- Kapağın kapatılmasıyla başlayan yıkama döngüsü
- Otomatik dolan yıkama tankı
- Emniyet termostati
- Manyetik kapak sivici
- Kullanıcı dostu kumanda arayüzü
- Yüksekliği ayarlanabilir ayaklar
- Parlaticı pompası dahildir
- Drenaj ve deterjan pompası bağlanabilme imkanı (opsiyonel)

General Features

- Stainless steel construction
- High quality stainless steel heaters
- Not simultaneously activated heating system provides energy saving
- Double walled door
- Rotating upper and lower washing arms
- Cycle start at door closing
- Automatic tank loading
- Safety thermostat
- Magnetic door switch
- User-friendly command interface
- Height adjustable feet
- Rinse aid pump included
- Drain and detergent pump can be connected to chasis (optional)

TEKNİK ÖZELLİKLER / TECHNICAL SPECIFICATIONS

Model / Model	GW-535 ECO
Güç girişi / Power input	220V/1/N ~ 50Hz
Su girişi / Water input	3/4"
Güç kaynağı / Power supply	Electric
Kumanda tipi / Command type	Analog
Yıkama periyodu (sn.) / Washing cycle (sec.)	120
Yıkama kapasitesi (sepet/s) / Washing capacity (basket/h)	30
Yıkama yüksekliği (mm) / Washing clearance (mm)	170
Yıkama tankı kapasitesi (lt) / Washing tank capacity (lt)	17
Boiler tankı kapasitesi (lt) / Boiler tank capacity (lt)	3,6
Yıkama sıcaklığı (°C) / Washing temperature (°C)	60-65
Durulama sıcaklığı (°C) / Rinsing temperature (°C)	70-80
Durulama su tüketimi (lt) / Rinsing water consumption (lt)	0,6
İç kabin yüksekliği (mm) / Internal cabinet height (mm)	160
Dinamik su giriş basıncı (bar) / Dynamic water input pressure (bar)	2-6
Dış ölçüler (WxDxH) (mm) / External dimensions (WxDxH) (mm)	440 x 500 x 680
Yıkama pompası gücü (kW) / Washing pump power (kW)	0,26
Tank ısıtıcı gücü (kW) / Tank heater power (kW)	1
Boiler ısıtıcısı gücü (kW) / Boiler heater power (kW)	2
Sepet ölçüleri (mm) / Basket dimensions (mm)	350 x 350 x 150
Toplam güç (kW) / Total power (kW)	3,3
Besleme gerilimi (V) / Voltage (V)	220V/1/N ~ 50Hz
Net ağırlık (kg) / Net weight (kg)	39
Brüt ağırlık (kg) / Gross weight (kg)	45

Genel Ölçüler / General Dimensions

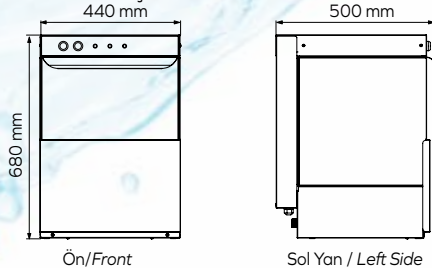

Opsiyonel Parçalar / Optional Parts

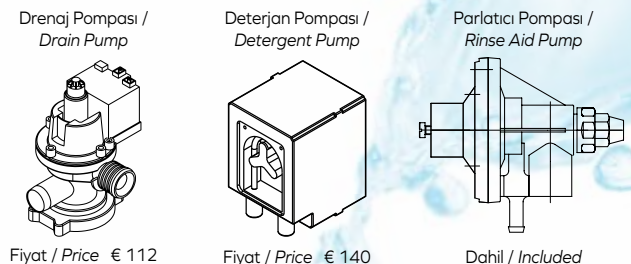

GW-640 ECO 1720 €

*Bardak Yıkama Makinesi
Glasswasher*



**600 bardak/saat
yıkama kapasitesi
40 x 40 cm sepet**

**600 glass/hour
washing capacity
40 x 40 cm basket**



Uluslararası standartlarda güvenlik uygunluğu
Safety conformation to international standarts



Otomatik parlatıcı pompası
Automatic rinse aid system



Kuvvetlendirilmiş plastik bileşenler
Reinforced plastic components



Dayanıklı kapak sistemi
Durable door arm system



Özel üretim parçalar
Special manufactured components

Genel Özellikler

- Paslanmaz çelik gövde ve şase
- Yüksek kalitede paslanmaz çelik ısıtıcılar
- Aynı anda devrede olmayan ısıtma sistemi ile enerji tasarrufu
- Çift cidarlı kapak
- Dönen alt ve üst yıkama kolları
- Kapağın kapatılmasıyla başlayan yıkama döngüsü
- Otomatik dolan yıkama tankı
- Emniyet termostati
- Manyetik kapak sivici
- Kullanıcı dostu kumanda arayüzü
- Yüksekliği ayarlanabilir ayaklar
- Parlaticı pompası dahildir
- Drenaj ve deterjan pompası bağlanabilme imkanı (opsiyonel)

General Features

- Stainless steel construction
- High quality stainless steel heaters
- Not simultaneously activated heating system provides energy saving
- Double walled door
- Rotating upper and lower washing arms
- Cycle start at door closing
- Automatic tank loading
- Safety thermostat
- Magnetic door switch
- User-friendly command interface
- Height adjustable feet
- Rinse aid pump included
- Drain and detergent pump can be connected to chasis (optional)

TEKNİK ÖZELLİKLER / TECHNICAL SPECIFICATIONS

Model / Model	GW-640 ECO
Güç girişi / Power input	220V/1/N ~ 50Hz
Su girişi / Water input	3/4"
Güç kaynağı / Power supply	Electric
Kumanda tipi / Command type	Analog
Yıkama periyodu (sn.) / Washing cycle (sec.)	120
Yıkama kapasitesi (sepet/s) / Washing capacity (basket/h)	30
Yıkama yüksekliği (mm) / Washing clearance (mm)	270
Yıkama tankı kapasitesi (lt) / Washing tank capacity (lt)	20
Boiler tankı kapasitesi (lt) / Boiler tank capacity (lt)	3,6
Yıkama sıcaklığı (°C) / Washing temperature (°C)	60-65
Durulama sıcaklığı (°C) / Rinsing temperature (°C)	70-80
Durulama su tüketimi (lt) / Rinsing water consumption (lt)	0,6
İç kabin yüksekliği (mm) / Internal cabinet height (mm)	270
Dinamik su giriş basıncı (bar) / Dynamic water input pressure (bar)	2-6
Dış ölçüler (WxDxH) (mm) / External dimensions (WxDxH) (mm)	490 x 570 x 780
Yıkama pompası gücü (kW) / Washing pump power (kW)	0,26
Tank ısıtıcı gücü (kW) / Tank heater power (kW)	1
Boiler ısıtıcısı gücü (kW) / Boiler heater power (kW)	2,5
Sepet ölçüleri (mm) / Basket dimensions (mm)	400 x 400 x 150
Toplam güç (kW) / Total power (kW)	3,8
Besleme gerilimi (V) / Voltage (V)	220V/1/N ~ 50Hz
Net ağırlık (kg) / Net weight (kg)	50
Brüt ağırlık (kg) / Gross weight (kg)	55

Genel Ölçüler / General Dimensions

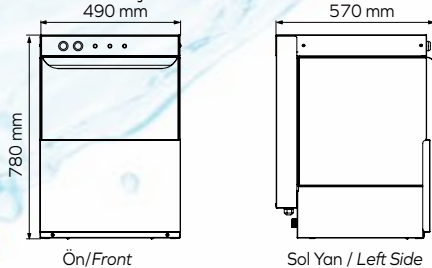

Opsiyonel Parçalar / Optional Parts

Drenaj Pompası /
Drain Pump

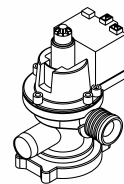

Fiyat / Price € 112

Deterjan Pompası /
Detergent Pump

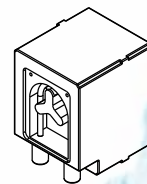

Fiyat / Price € 140

Parlaticı Pompası /
Rinse Aid Pump

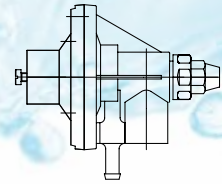

Dahil / Included

DW-500 ECO

1900 €

Set Altı Bulaşık Yıkama Makinesi
Undercounter Dishwasher



500 tabak/saat
yıkama kapasitesi
50 x 50 cm sepet
500 dishes/hour
washing capacity
50 x 50 cm basket



Uluslararası standartlarda güvenlik uygunluğu
Safety conformation to international standarts



Kolay kullanıma sahip kumanda paneli
Easy to use control panel



Kuvvetlendirilmiş plastik bileşenler
Reinforced plastic components



Sağlamlaştırılmış şase
Hardened chasis



Dayanıklı kapak sistemi
Durable door arm system

Genel Özellikler

- Paslanmaz çelik gövde ve şase
- Yüksek kalitede paslanmaz çelik ısıtıcılar
- Aynı anda devrede olmayan ısıtma sistemi ile enerji tasarrufu
- Çift cidarlı kapak
- Dönen alt ve üst yıkama kolları
- Kapağın kapatılmasıyla başlayan yıkama döngüsü
- Otomatik dolan yıkama tankı
- Emniyet termostati
- Manyetik kapak sivici
- Kullanıcı dostu kumanda arayüzü
- Yüksekliği ayarlanabilir ayaklar
- Drenaj, deterjan ve parlatıcı pompası bağlanabilme imkanı (opsiyonel)

General Features

- Stainless steel construction
- High quality stainless steel heaters
- Not simultaneously activated heating system provides energy saving
- Double walled door
- Rotating upper and lower washing arms
- Cycle start at door closing
- Automatic tank loading
- Safety thermostat
- Magnetic door switch
- User-friendly command interface
- Height adjustable feet
- Drain, detergent and rinse aid pump can be connected to chasis (optional)

TEKNİK ÖZELLİKLER / TECHNICAL SPECIFICATIONS

Model / Model	DW-500 ECO
Güç girişi / Power input	220V/1/N ~ 50Hz
Su girişi / Water input	3/4"
Güç kaynağı / Power supply	Electric
Kumanda tipi / Command type	Analog
Yıkama periyodu (sn.) / Washing cycle (sec.)	120
Yıkama kapasitesi (sepet/s) / Washing capacity (basket/h)	30
Yıkama yüksekliği (mm) / Washing clearance (mm)	310
Yıkama tankı kapasitesi (lt) / Washing tank capacity (lt)	27
Boiler tankı kapasitesi (lt) / Boiler tank capacity (lt)	6,1
Yıkama sıcaklığı (°C) / Washing temperature (°C)	60-65
Durulama sıcaklığı (°C) / Rinsing temperature (°C)	80-85
Durulama su tüketimi (lt) / Rinsing water consumption (lt)	0,8
İç kabin yüksekliği (mm) / Internal cabinet height (mm)	360
Dinamik su giriş basıncı (bar) / Dynamic water input pressure (bar)	2-6
Dış ölçüler (WxDxH) (mm) / External dimensions (WxDxH) (mm)	590 x 670 x 820
Yıkama pompası gücü (kW) / Washing pump power (kW)	0,65
Tank ısıtıcı gücü (kW) / Tank heater power (kW)	2
Boiler ısıtıcısı gücü (kW) / Boiler heater power (kW)	4
Sepet ölçüleri (mm) / Basket dimensions (mm)	500 x 500 x 100
Toplam güç (kW) / Total power (kW)	6,65
Besleme gerilimi (V) / Voltage (V)	220V/1/N ~ 50Hz
Net ağırlık (kg) / Net weight (kg)	60
Brüt ağırlık (kg) / Gross weight (kg)	66

Genel Ölçüler / General Dimensions

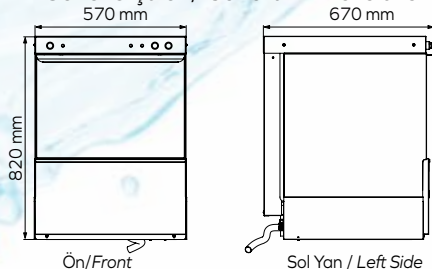

Opsiyonel Parçalar / Optional Parts

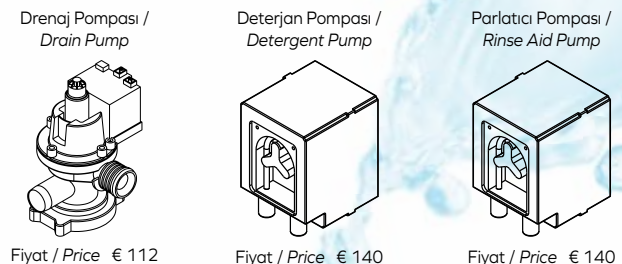

DW-1000 ECO 2520 €

Giyotin Tipi Bulaşık Yıkama Makinesi
Pass Through Hood Type
Dishwasher



1000 tabak/saat
yıkama kapasitesi
50 x 50 cm sepet
1000 dishes/hour
washing capacity
50 x 50 cm basket



Paslanmaz çelik kolektörler
Stainless steel collectors



Ayarlanabilir sepet dayama aparatı
Adjustable basket bracket



Kuvvetlendirilmiş plastik bileşenler
Reinforced plastic components



Uluslararası standartlarda güvenlik uygunluğu
Safety conformation to international standards



Özel üretim parçalar
Special manufactured components

Genel Özellikler

- Paslanmaz çelik gövde ve şase
- 4 tip yıkama programı
- Yüksek kalitede paslanmaz çelik ısıtıcılar
- Dönen alt ve üst yıkama kolları
- Kapağın kapatılmasıyla başlayan yıkama döngüsü
- Otomatik dolan yıkama tankı
- Emniyet termostati
- Kullanıcı dostu kumanda arayüzü
- Yüksekliği ayarlanabilir ayaklar
- Entegre tank filtresi
- Drenaj, durulama, deterjan ve parlatıcı pompası bağlanabilme imkanı (opsiyonel)

General Features

- Stainless steel construction
- 4 type washing programs
- High quality stainless steel heaters
- Rotating upper and lower washing arms
- Cycle start at door closing
- Automatic tank loading
- Safety thermostat
- User-friendly command interface
- Height adjustable feet
- Integral tank filter
- Drain, rinsing boost, detergent and rinse aid pump can be connected to chasis (optional)

TEKNİK ÖZELLİKLER / TECHNICAL SPECIFICATIONS

Model / Model	DW-1000 ECO
Güç girişi / Power input	380V/3/N ~ 50Hz
Su girişi / Water input	3/4"
Güç kaynağı / Power supply	Electric
Kumanda tipi / Command type	Analog
Yıkama periyodu (sn.) / Washing cycle (sec.)	60-90-120-180
Yıkama kapasitesi (sepet/s) / Washing capacity (basket/h)	60
Yıkama yüksekliği (mm) / Washing clearance (mm)	380
Yıkama tankı kapasitesi (lt) / Washing tank capacity (lt)	45
Boiler tankı kapasitesi (lt) / Boiler tank capacity (lt)	8,6
Yıkama sıcaklığı (°C) / Washing temperature (°C)	60-65
Durulama sıcaklığı (°C) / Rinsing temperature (°C)	80-85
Durulama su tüketimi (lt) / Rinsing water consumption (lt)	0,9
İç kabin yüksekliği (mm) / Internal cabinet height (mm)	430
Dinamik su giriş basıncı (bar) / Dynamic water input pressure (bar)	2-6
Dış ölçüler (WxDxH) (mm) / External dimensions (WxDxH) (mm)	660 x 810 x 1390-1800
Yıkama pompası gücü (kW) / Washing pump power (kW)	0,65
Tank ısıtıcı gücü (kW) / Tank heater power (kW)	3
Boiler ısıtıcısı gücü (kW) / Boiler heater power (kW)	6
Sepet ölçüleri (mm) / Basket dimensions (mm)	500 x 500 x 100
Toplam güç (kW) / Total power (kW)	9,65
Besleme gerilimi (V) / Voltage (V)	380V/3/N ~ 50Hz
Net ağırlık (kg) / Net weight (kg)	87
Brüt ağırlık (kg) / Gross weight (kg)	95

Genel Ölçüler / General Dimensions

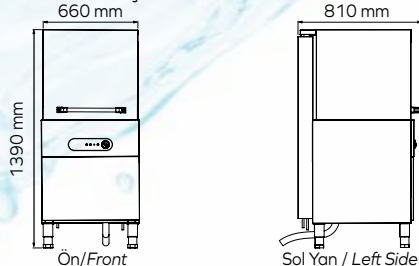

Opsiyonel Parçalar / Optional Parts

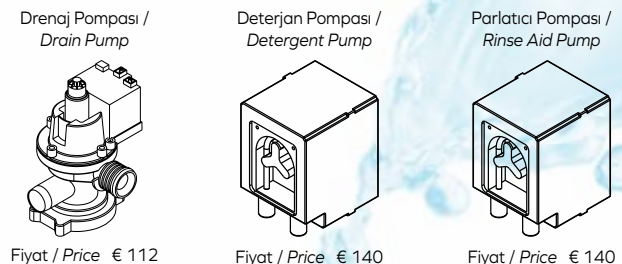

GW-535

1740 €



Bardak Yıkama Makinesi
Glasswasher



500 bardak/saat
yıkama kapasitesi
35 x 35 cm sepet

500 glass/hour
washing capacity
35 x 35 cm basket



Uluslararası standartlarda güvenlik uygunluğu
Safety conformation to international standarts



Otomatik parlatıcı pompası
Automatic rinse aid system



Kuvvetlendirilmiş plastik bileşenler
Reinforced plastic components



Dayanıklı kapak sistemi
Durable door arm system



Sağlamlaştırılmış gövde
Hardened chasis

Genel Özellikler

- 18/10 304 AISI paslanmaz çelik gövde ve şase
- 9 tip yıkama programı
- Boyler ve kazan sıcaklık göstergesi
- Gösterge panelinden arıza kodları ile arıza tespiti
- Yüksek kalitede paslanmaz çelik ısıtıcılar
- Aynı anda devrede olmayan ısıtma sistemi ile enerji tasarrufu
- Çift cidarlı kapak
- Dönen alt ve üst yıkama kolları
- Kapağın kapatılmasıyla başlayan yıkama döngüsü
- Otomatik dolan yıkama tankı
- Emniyet termostatu
- Manyetik kapak sivici
- Kullanıcı dostu kumanda arayüzü
- Yüksekliği ayarlanabilir ayaklar
- Parlatıcı pompası dahildir
- Drenaj ve deterjan pompası bağlanabilme imkanı (opsiyonel)

General Features

- 18/10 AISI 304 stainless steel construction
- 9 type washing programs
- Boiler and tank temperature display
- Fault detection with fault codes from the display panel
- High quality stainless steel heaters
- Not simultaneously activated heating system provides energy saving
- Double walled door
- Rotating upper and lower washing arms
- Cycle start at door closing
- Automatic tank loading
- Safety thermostat
- Magnetic door switch
- User-friendly command interface
- Height adjustable feet
- Rinse aid pump included
- Drain and detergent pump can be connected to chasis (optional)

TEKNİK ÖZELLİKLER / TECHNICAL SPECIFICATIONS

Model / Model	GW-535
Güç girişi / Power input	220V/1/N ~ 50Hz
Su girişi / Water input	3/4"
Güç kaynağı / Power supply	Electric
Kumanda tipi / Command type	Digital
Yıkama periyodu (sn.) / Washing cycle (sec.)	60-90-120-150-180-210-240-270-300
Yıkama kapasitesi (sepet/s) / Washing capacity (basket/h)	30
Yıkama yüksekliği (mm) / Washing clearance (mm)	170
Yıkama tankı kapasitesi (lt) / Washing tank capacity (lt)	17
Boiler tankı kapasitesi (lt) / Boiler tank capacity (lt)	3,6
Yıkama sıcaklığı (°C) / Washing temperature (°C)	60-65
Durulama sıcaklığı (°C) / Rinsing temperature (°C)	70-80
Durulama su tüketimi (lt) / Rinsing water consumption (lt)	0,6
İç kabin yüksekliği (mm) / Internal cabinet height (mm)	160
Dinamik su giriş basıncı (bar) / Dynamic water input pressure (bar)	2-6
Dış ölçüler (WxDxH) (mm) / External dimensions (WxDxH) (mm)	440 x 500 x 680
Yıkama pompası gücü (kW) / Washing pump power (kW)	0,26
Tank ısıtıcı gücü (kW) / Tank heater power (kW)	1
Boiler ısıtıcısı gücü (kW) / Boiler heater power (kW)	2
Sepet ölçüleri (mm) / Basket dimensions (mm)	350 x 350 x 150
Toplam güç (kW) / Total power (kW)	3,3
Besleme gerilimi (V) / Voltage (V)	220V/1/N ~ 50Hz
Net ağırlık (kg) / Net weight (kg)	39
Brüt ağırlık (kg) / Gross weight (kg)	45

Genel Ölçüler / General Dimensions

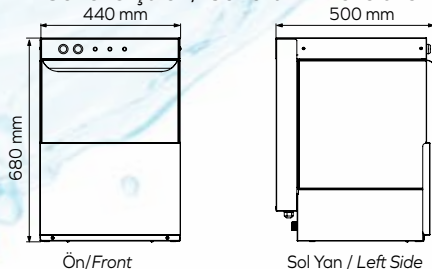

Opsiyonel Parçalar / Optional Parts

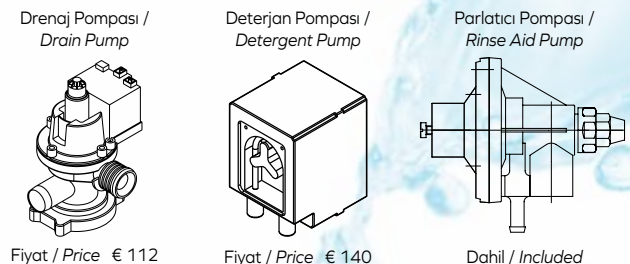

GW-640

1840 €



Bardak Yıkama Makinesi
Glasswasher



600 bardak/saat
yıkama kapasitesi
40 x 40 cm sepet

600 glass/hour
washing capacity
40 x 40 cm basket



Uluslararası standartlarda güvenlik uygunluğu
Safety conformation to international standarts



Otomatik parlatıcı pompası
Automatic rinse aid system



Kuvvetlendirilmiş plastik bileşenler
Reinforced plastic components



Dayanıklı kapak sistemi
Durable door arm system



Sağlamlaştırılmış gövde
Hardened chasis

Genel Özellikler

- 18/10 304 AISI paslanmaz çelik gövde ve şase
- 9 tip yıkama programı
- Boyler ve kazan sıcaklık göstergesi
- Gösterge panelinden arıza kodları ile arıza tespiti
- Yüksek kalitede paslanmaz çelik ısıtıcılar
- Aynı anda devrede olmayan ısıtma sistemi ile enerji tasarrufu
- Çift cidarlı kapak
- Dönen alt ve üst yıkama kolları
- Kapağın kapatılmasıyla başlayan yıkama döngüsü
- Otomatik dolan yıkama tankı
- Emniyet termostati
- Manyetik kapak sivici
- Kullanıcı dostu kumanda arayüzü
- Yüksekliği ayarlanabilir ayaklar
- Parlaticı pompası dahildir
- Drenaj ve deterjan pompası bağlanabilme imkanı (opsiyonel)

General Features

- 18/10 AISI 304 stainless steel construction
- 9 type washing programs
- Boiler and tank temperature display
- Fault detection with fault codes from the display panel
- High quality stainless steel heaters
- Not simultaneously activated heating system provides energy saving
- Double walled door
- Rotating upper and lower washing arms
- Cycle start at door closing
- Automatic tank loading
- Safety thermostat
- Magnetic door switch
- User-friendly command interface
- Height adjustable feet
- Rinse aid pump included
- Drain and detergent pump can be connected to chasis (optional)

TEKNİK ÖZELLİKLER / TECHNICAL SPECIFICATIONS

Model / Model	GW-640
Güç girişi / Power input	220V/1/N ~ 50Hz
Su girişi / Water input	3/4"
Güç kaynağı / Power supply	Electric
Kumanda tipi / Command type	Digital
Yıkama periyodu (sn.) / Washing cycle (sec.)	60-90-120-150-180-210-240-270-300
Yıkama kapasitesi (sepet/s) / Washing capacity (basket/h)	30
Yıkama yüksekliği (mm) / Washing clearance (mm)	270
Yıkama tankı kapasitesi (lt) / Washing tank capacity (lt)	20
Boylar tankı kapasitesi (lt) / Boiler tank capacity (lt)	3,6
Yıkama sıcaklığı (°C) / Washing temperature (°C)	60-65
Durulama sıcaklığı (°C) / Rinsing temperature (°C)	70-80
Durulama su tüketimi (lt) / Rinsing water consumption (lt)	0,6
İç kabin yüksekliği (mm) / Internal cabinet height (mm)	270
Dinamik su giriş basıncı (bar) / Dynamic water input pressure (bar)	2-6
Dış ölçüler (WxDxH) (mm) / External dimensions (WxDxH) (mm)	490 x 570 x 780
Yıkama pompası gücü (kW) / Washing pump power (kW)	0,26
Tank ısıtıcı gücü (kW) / Tank heater power (kW)	1
Boylar ısıtıcısı gücü (kW) / Boiler heater power (kW)	2,5
Sepet ölçüleri (mm) / Basket dimensions (mm)	400 x 400 x 150
Toplam güç (kW) / Total power (kW)	3,8
Besleme gerilimi (V) / Voltage (V)	220V/1/N ~ 50Hz
Net ağırlık (kg) / Net weight (kg)	50
Brüt ağırlık (kg) / Gross weight (kg)	55

Genel Ölçüler / General Dimensions

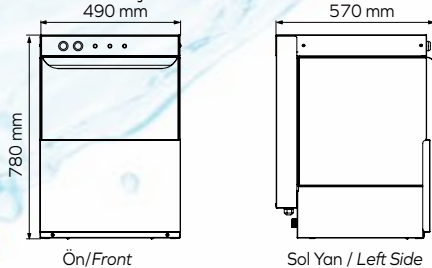

Opsiyonel Parçalar / Optional Parts

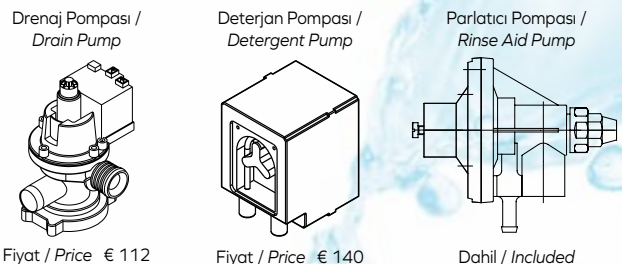

DW-500

2060 €



Set Altı Bulaşık Yıkama Makinesi
Undercounter Dishwasher



500 tabak/saat
yıkama kapasitesi
50 x 50 cm sepet
500 dishes/hour
washing capacity
50 x 50 cm basket



Uluslararası standartlarda güvenlik uygunluğu
Safety conformation to international standarts



Kolay kullanıma sahip kumanda paneli
Easy to use control panel



Kuvvetlendirilmiş plastik bileşenler
Reinforced plastic components



Sağlamlaştırılmış şase
Hardened chasis



Dayanıklı kapak sistemi
Durable door arm system

Genel Özellikler

- 18/10 304 AISI paslanmaz çelik gövde ve şase
- 9 tip yıkama programı
- Boyler ve kazan sıcaklık göstergesi
- Gösterge panelinden arıza kodları ile arıza tespiti
- Yüksek kalitede paslanmaz çelik ısıtıcılar
- Aynı anda devrede olmayan ısıtma sistemi ile enerji tasarrufu
- Çift cidarlı kapak
- Dönen alt ve üst yıkama kolları
- Kapağın kapatılmasıyla başlayan yıkama döngüsü
- Otomatik dolan yıkama tankı
- Emniyet termostati
- Manyetik kapak sivici
- Kullanıcı dostu kumanda arayüzü
- Yüksekliği ayarlanabilir ayaklar
- Drenaj, deterjan ve parlatıcı pompası bağlanabilme imkanı (opsiyonel)

General Features

- 18/10 AISI 304 stainless steel construction
- 9 type washing programs
- Boiler and tank temperature display
- Fault detection with fault codes from the display panel
- High quality stainless steel heaters
- Not simultaneously activated heating system provides energy saving
- Double walled door
- Rotating upper and lower washing arms
- Cycle start at door closing
- Automatic tank loading
- Safety thermostat
- Magnetic door switch
- User-friendly command interface
- Height adjustable feet
- Drain, detergent and rinse aid pump can be connected to chasis (optional)

TEKNİK ÖZELLİKLER / TECHNICAL SPECIFICATIONS

Model / Model	DW-500
Güç girişi / Power input	220V/1/N ~ 50Hz
Su girişi / Water input	3/4"
Güç kaynağı / Power supply	Electric
Kumanda tipi / Command type	Digital
Yıkama periyodu (sn.) / Washing cycle (sec.)	60-90-120-150-180-210-240-270-300
Yıkama kapasitesi (sepet/s) / Washing capacity (basket/h)	30
Yıkama yüksekliği (mm) / Washing clearance (mm)	310
Yıkama tankı kapasitesi (lt) / Washing tank capacity (lt)	27
Boiler tankı kapasitesi (lt) / Boiler tank capacity (lt)	6,1
Yıkama sıcaklığı (°C) / Washing temperature (°C)	60-65
Durulama sıcaklığı (°C) / Rinsing temperature (°C)	80-85
Durulama su tüketimi (lt) / Rinsing water consumption (lt)	0,8
İç kabin yüksekliği (mm) / Internal cabinet height (mm)	360
Dinamik su giriş basıncı (bar) / Dynamic water input pressure (bar)	2-6
Dış ölçüler (WxDxH) (mm) / External dimensions (WxDxH) (mm)	590 x 670 x 820
Yıkama pompası gücü (kW) / Washing pump power (kW)	0,65
Tank ısıtıcı gücü (kW) / Tank heater power (kW)	2
Boiler ısıtıcısı gücü (kW) / Boiler heater power (kW)	4
Sepet ölçüleri (mm) / Basket dimensions (mm)	500 x 500 x 100
Toplam güç (kW) / Total power (kW)	6,65
Besleme gerilimi (V) / Voltage (V)	220V/1/N ~ 50Hz
Net ağırlık (kg) / Net weight (kg)	60
Brüt ağırlık (kg) / Gross weight (kg)	66

Genel Ölçüler / General Dimensions

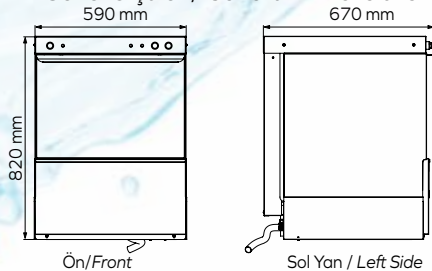

Opsiyonel Parçalar / Optional Parts

Drenaj Pompası / Drain Pump

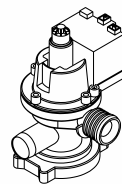

Fiyat / Price € 112

Deterjan Pompası / Detergent Pump

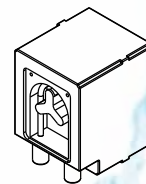

Fiyat / Price € 140

Parlatıcı Pompası / Rinse Aid Pump

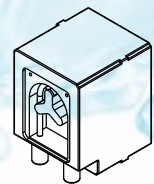

Fiyat / Price € 140

DW-1000

2860 €



Giyotin Tipi Bulaşık Yıkama Makinesi
Pass Through Hood Type
Dishwasher



1000 tabak/saat
yıkama kapasitesi
50 x 50 cm sepet
1000 dishes/hour
washing capacity
50 x 50 cm basket



Paslanmaz çelik kolektörler
Stainless steel collectors



Ayarlanabilir sepet dayama aparatı
Adjustable basket bracket



Kuvvetlendirilmiş plastik bileşenler
Reinforced plastic components



Sağlamlaştırılmış şase
Hardened chassis



Uluslararası standartlarda güvenlik uygunluğu
Safety conformance to international standards

Genel Özellikler

- 18/10 304 AISI paslanmaz çelik gövde ve şase
- 9 tip yıkama programı
- Boyler ve kazan sıcaklık göstergesi
- Gösterge panelinden arıza kodları ile arıza tespiti
- Yüksek kalitede paslanmaz çelik ısıtıcılar
- Dönen alt ve üst yıkama kolları
- Kapağın kapatılmasıyla başlayan yıkama döngüsü
- Otomatik dolan yıkama tankı
- Emniyet termostati
- Kullanıcı dostu kumanda arayüzü
- Yüksekliği ayarlanabilir ayaklar
- Entegre tank filtresi
- Drenaj, durulama, deterjan ve parlatıcı pompası bağlanabilme imkanı (opsiyonel)

General Features

- 18/10 AISI 304 stainless steel construction
- 9 type washing programs
- Boiler and tank temperature display
- Fault detection with fault codes from the display panel
- High quality stainless steel heaters
- Rotating upper and lower washing arms
- Cycle start at door closing
- Automatic tank loading
- Safety thermostat
- User-friendly command interface
- Height adjustable feet
- Integral tank filter
- Drain, rinsing boost, detergent and rinse aid pump can be connected to chasis (optional)

TEKNİK ÖZELLİKLER / TECHNICAL SPECIFICATIONS

Model / Model	DW-1000
Güç girişi / Power input	380V/3/N ~ 50Hz
Su girişi / Water input	3/4"
Güç kaynağı / Power supply	Electric
Kumanda tipi / Command type	Digital
Yıkama periyodu (sn.) / Washing cycle (sec.)	60-90-120-150-180-210-240-270-300
Yıkama kapasitesi (sepet/s) / Washing capacity (basket/h)	60
Yıkama yüksekliği (mm) / Washing clearance (mm)	380
Yıkama tankı kapasitesi (lt) / Washing tank capacity (lt)	45
Boylar tankı kapasitesi (lt) / Boiler tank capacity (lt)	8,6
Yıkama sıcaklığı (°C) / Washing temperature (°C)	60-65
Durulama sıcaklığı (°C) / Rinsing temperature (°C)	80-85
Durulama su tüketimi (lt) / Rinsing water consumption (lt)	0,9
İç kabin yüksekliği (mm) / Internal cabinet height (mm)	430
Dinamik su giriş basıncı (bar) / Dynamic water input pressure (bar)	2-6
Dış ölçüler (WxDxH) (mm) / External dimensions (WxDxH) (mm)	660 x 810 x 1390-1800
Yıkama pompası gücü (kW) / Washing pump power (kW)	0,65
Tank ısıtıcı gücü (kW) / Tank heater power (kW)	3
Boylar ısıtıcısı gücü (kW) / Boiler heater power (kW)	6
Sepet ölçüleri (mm) / Basket dimensions (mm)	500 x 500 x 100
Toplam güç (kW) / Total power (kW)	9,65
Besleme gerilimi (V) / Voltage (V)	380V/3/N ~ 50Hz
Net ağırlık (kg) / Net weight (kg)	87
Brüt ağırlık (kg) / Gross weight (kg)	95

Genel Ölçüler / General Dimensions

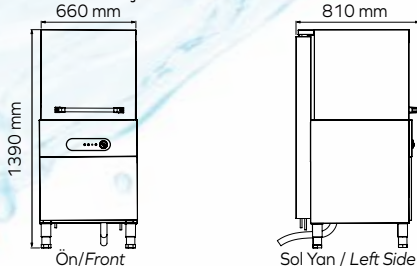

Opsiyonel Parçalar / Optional Parts

Drenaj Pompası / Drain Pump

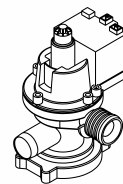

Fiyat / Price € 112

Deterjan Pompası / Detergent Pump

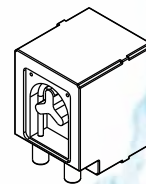

Fiyat / Price € 160

Parlatıcı Pompası / Rinse Aid Pump

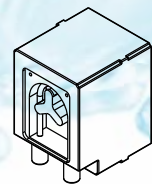

Fiyat / Price € 160

DW-2000

10700 €

Konveyörlü Tip Bulaşık Yıkama Makinesi
Conveyor Type Dishwasher



2000 tabak/saat
yıkama kapasitesi
50 x 50 cm sepet
2000 dishes/hour
washing capacity
50 x 50 cm basket



Sağlamlaştırılmış konveyör taşıma hattı
Reinforced conveyor carrying line



Sağlamlaştırılmış konveyör taşıma hattı
Reinforced conveyor carrying line



Temizlenebilir yıkama kolları
Cleanable washing arms



Kullanıcı dostu kumanda ara yüzü
User-friendly control interface



Acil durdurma butonu
Emergency stop button

Genel Özellikler

- 18/10 304 AISI paslanmaz çelik gövde ve şase
- Yüksek kalitede paslanmaz çelik ısıtıcılar
- Kapağın kapatılmasıyla başlayan yıkama işlemi
- Dijital sıcaklık göstergeleri (opsiyonel)
- Çift hız kademeli konveyör sistem (opsiyonel)
- Avrupa üretimi motorlar
- Soğuk su ve sıcak su bağlantı imkanı
- Sıcak su bağlantısına dayanıklı komponentler sayesinde düşük elektrik tüketimi imkanı
- Bağımsız ön yıkama ve yıkama tankı
- Ön ısıtmalı boiler tank sistemi
- Emniyet termostatları
- Kullanıcı dostu kumanda arayüzü
- Yüksekliği ayarlanabilir ayaklar
- Güvenlik için acil durdurma butonu
- Ön yıkama, yıkama, durulama ve kurutma aşamaları
- Entegre tank filtresi
- Durulama, deterjan ve parlaticı pompası bağlanabilme imkanı (opsiyonel)

General Features

- 18/10 AISI 304 stainless steel construction
- High quality stainless steel heaters
- Cycle start at door closing
- Digital temperature display (optional)
- Conveyor system with dual-stage speed (optional)
- Motors are made in Europe
- Cold water and hot water connection possibility
- Low electricity consumption thanks to components resistant to hot water connection
- Individual pre-wash and wash tank
- Pre-heated boiler tank system
- Safety switches
- User-friendly control interface
- Height-adjustable legs
- Emergency stop button for safety
- Prewashing, washing, rinsing and drying stages
- Rinsing boost, detergent and rinse aid pump can be connected to chasis (optional)

TEKNİK ÖZELLİKLER / TECHNICAL SPECIFICATIONS

Model / Model	DW-2000
Güç girişi / Power input	380V/3/N ~ 50Hz
Su girişi / Water input	3/4"
Güç kaynağı / Power supply	Electric
Kumanda tipi / Command type	Analog
Yıkama periyodu (sn.) / Washing cycle (sec.)	Sürekli/Continuous
Yıkama kapasitesi (sepet/s) / Washing capacity (basket/h)	120
Yıkama yüksekliği (mm) / Washing clearance (mm)	480
Yıkama tankı kapasitesi (lt) / Washing tank capacity (lt)	60+50
Boiler tankı kapasitesi (lt) / Boiler tank capacity (lt)	8,5+13
Yıkama sıcaklığı (°C) / Washing temperature (°C)	60-65
Durulama sıcaklığı (°C) / Rinsing temperature (°C)	80-85
Durulama su tüketimi (lt) / Rinsing water consumption (lt)	3-4
İç kabin yüksekliği (mm) / Internal cabinet height (mm)	480
Dinamik su giriş basıncı (bar) / Dynamic water input pressure (bar)	2-6
Dış ölçüler (WxDxH) (mm) / External dimensions (WxDxH) (mm)	2530 x 815 x 1800
Yıkama pompası gücü (kW) / Washing pump power (kW)	1,1+1,1
Tank ısıtıcı gücü (kW) / Tank heater power (kW)	4+6
Boiler ısıtıcısı gücü (kW) / Boiler heater power (kW)	6+16
Sepet ölçüleri (mm) / Basket dimensions (mm)	500 x 500 x 100
Toplam güç (kW) / Total power (kW)	43,5
Besleme gerilimi (V) / Voltage (V)	380V/3/N ~ 50Hz
Net ağırlık (kg) / Net weight (kg)	255
Brüt ağırlık (kg) / Gross weight (kg)	280

Genel Ölçüler / General Dimensions

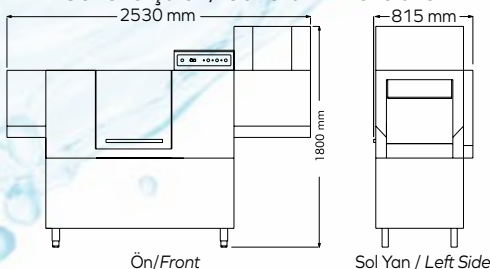

Opsiyonel Parçalar / Optional Parts

Çift hız kademeli Konveyör Sistemi / Conveyor System with dual-stage speed

Dijital Sıcaklık Göstergeleri / Digital Temperature Displays

Fiyat / Price € 340

Deterjan Pompası / Detergent Pump

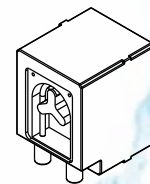

Fiyat / Price € 160

Parlaticı Pompası / Rinse Aid Pump

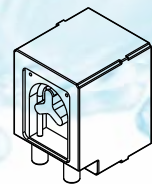

Fiyat / Price € 160

DW-3000

11550 €

Konveyörlü Tip Bulaşık Yıkama Makinesi
Conveyor Type Dishwasher



3000 tabak/saat
yıkama kapasitesi
50 x 50 cm sepet
3000 dishes/hour
washing capacity
50 x 50 cm basket



Sağlamlaştırılmış konveyör taşıma hattı
Reinforced conveyor carrying line



Sağlamlaştırılmış konveyör taşıma hattı
Reinforced conveyor carrying line



Temizlenebilir yıkama kolları
Cleanable washing arms



Kullanıcı dostu kumanda ara yüzü
User-friendly control interface



Acil durdurma butonu
Emergency stop button

Genel Özellikler

- 18/10 304 AISI paslanmaz çelik gövde ve şase
- Yüksek kalitede paslanmaz çelik ısıtıcılar
- Kapağın kapatılmasıyla başlayan yıkama işlemi
- Dijital sıcaklık göstergeleri (opsiyonel)
- Çift hız kademeli konveyör sistem (opsiyonel)
- Avrupa üretimi motorlar
- Soğuk su ve sıcak su bağlantı imkanı
- Sıcak su bağlantısına dayanıklı komponentler sayesinde düşük elektrik tüketimi imkanı
- Bağımsız ön yıkama ve yıkama tankı
- Ön ısıtmalı boiler tank sistemi
- Emniyet termostatları
- Kullanıcı dostu kumanda arayüzü
- Yüksekliği ayarlanabilir ayaklar
- Güvenlik için acil durdurma butonu
- Ön yıkama, yıkama, durulama ve kurutma aşamaları
- Entegre tank filtresi
- Durulama, deterjan ve parlatıcı pompası bağlanabilme imkanı (opsiyonel)

General Features

- 18/10 AISI 304 stainless steel construction
- High quality stainless steel heaters
- Cycle start at door closing
- Digital temperature display (optional)
- Conveyor system with dual-stage speed (optional)
- Motors are made in Europe
- Cold water and hot water connection possibility
- Low electricity consumption thanks to components resistant to hot water connection
- Individual pre-wash and wash tank
- Pre-heated boiler tank system
- Safety switches
- User-friendly control interface
- Height-adjustable legs
- Emergency stop button for safety
- Prewashing, washing, rinsing and drying stages
- Rinsing boost, detergent and rinse aid pump can be connected to chasis (optional)

TEKNİK ÖZELLİKLER / TECHNICAL SPECIFICATIONS

Model / Model	DW-3000
Güç girişi / Power input	380V/3/N ~ 50Hz
Su girişi / Water input	3/4"
Güç kaynağı / Power supply	Electric
Kumanda tipi / Command type	Analog
Yıkama periyodu (sn.) / Washing cycle (sec.)	Sürekli/Continuous
Yıkama kapasitesi (sepet/s) / Washing capacity (basket/h)	170
Yıkama yüksekliği (mm) / Washing clearance (mm)	480
Yıkama tankı kapasitesi (lt) / Washing tank capacity (lt)	70+60
Boiler tankı kapasitesi (lt) / Boiler tank capacity (lt)	13+13
Yıkama sıcaklığı (°C) / Washing temperature (°C)	60-65
Durulama sıcaklığı (°C) / Rinsing temperature (°C)	80-85
Durulama su tüketimi (lt) / Rinsing water consumption (lt)	3-4
İç kabin yüksekliği (mm) / Internal cabinet height (mm)	480
Dinamik su giriş basıncı (bar) / Dynamic water input pressure (bar)	2-6
Dış ölçüler (WxDxH) (mm) / External dimensions (WxDxH) (mm)	3035 x 815 x 1800
Yıkama pompası gücü (kW) / Washing pump power (kW)	1,1+1,1
Tank ısıtıcı gücü (kW) / Tank heater power (kW)	4+6
Boiler ısıtıcısı gücü (kW) / Boiler heater power (kW)	12+16
Sepet ölçüleri (mm) / Basket dimensions (mm)	500 x 500 x 100
Toplam güç (kW) / Total power (kW)	49,5
Besleme gerilimi (V) / Voltage (V)	380V/3/N ~ 50Hz
Net ağırlık (kg) / Net weight (kg)	315
Brüt ağırlık (kg) / Gross weight (kg)	340

Genel Ölçüler / General Dimensions

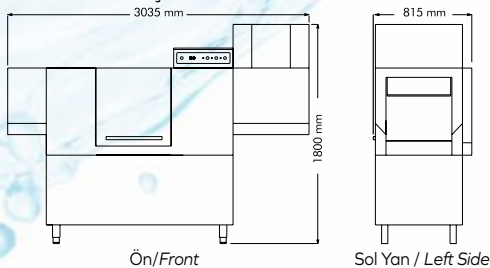

Opsiyonel Parçalar / Optional Parts

Çift hız kademeli Konveyör Sistemi / Conveyor System with dual-stage speed

Dijital Sıcaklık Göstergeleri / Digital Temperature Displays

Fiyat / Price € 340

Deterjan Pompası / Detergent Pump

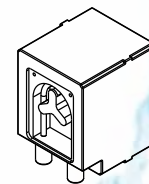

Fiyat / Price € 160

Parlatıcı Pompası / Rinse Aid Pump

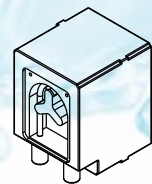

Fiyat / Price € 160

DW-4500 MODÜLER

17600 €



*Konveyörlü Tip
Bulaşık Yıkama Makinesi
Conveyor Type Dishwasher*



**4500 tabak/saat
yıkama kapasitesi
50 x 50 cm sepet**
**4500 dishes/hour
washing capacity
50 x 50 cm basket**



DW-4500 Aşamalar

- 1- Ön Yıkama Modülü
- 2- Yıkama Modülü 2 adet
- 3- Durulama Modülü
- 4- Kurutma Modülü (Alt ve üst kurutma)

DW-4500 Stages

- 1- Pre-washing Module
- 2- Washing Modules 2 pieces
- 3- Rinsing Module
- 4- Drying Module (Lower and upper drying)



Sağlamlaştırılmış konveyör taşıma hattı
Reinforced conveyor carrying line



Sağlamlaştırılmış konveyör taşıma hattı
Reinforced conveyor carrying line



Temizlenebilir yıkama kolları
Cleanable washing arms



Kullanıcı dostu kumanda ara yüzü
User-friendly control interface



Acil durdurma butonu
Emergency stop button

Genel Özellikler

- 18/10 304 AISI paslanmaz çelik gövde ve şase
- Yüksek kalitede paslanmaz çelik ısıtıcılar
- Kapağın kapatılmasıyla başlayan yıkama işlemi
- Dijital sıcaklık göstergeleri (opsiyonel)
- Avrupa üretimi motorlar
- Soğuk su ve sıcak su bağlantı imkanı
- Sıcak su bağlantısına dayanıklı komponentler sayesinde düşük elektrik tüketimi imkanı
- Bağımsız ön yıkama ve yıkama tankı
- Ön ısıtmalı boiler tank sistemi
- Emniyet termostatları
- Kullanıcı dostu kumanda arayüzü
- Yüksekliği ayarlanabilir ayaklar
- Güvenlik için acil durdurma butonu
- Ön yıkama, yıkama, durulama ve kurutma aşamaları
- Entegre tank filtresi
- Durulama, deterjan ve parlatıcı pompası bağlanabilme imkanı (opsiyonel)

General Features

- 18/10 AISI 304 stainless steel construction
- High quality stainless steel heaters
- Cycle start at door closing
- Digital temperature display (optional)
- Motors are made in Europe
- Cold water and hot water connection possibility
- Low electricity consumption thanks to components resistant to hot water connection
- Individual pre-wash and wash tank
- Pre-heated boiler tank system
- Safety switches
- User-friendly control interface
- Height-adjustable legs
- Emergency stop button for safety
- Prewashing, washing, rinsing and drying stages
- Rinsing boost, detergent and rinse aid pump can be connected to chasis (optional)

TEKNİK ÖZELLİKLER / TECHNICAL SPECIFICATIONS

Model / Model	DW-4500
Güç girişi / Power input	380V/3/N ~ 50Hz
Su girişi / Water input	3x3/4"
Güç kaynağı / Power supply	Electric
Kumanda tipi / Command type	Analog
Yıkama periyodu (sn.) / Washing cycle (sec.)	Sürekli/Continuous
Yıkama kapasitesi (sepet/s) / Washing capacity (basket/h)	280
Yıkama yüksekliği (mm) / Washing clearance (mm)	480
Yıkama tankı kapasitesi (lt) / Washing tank capacity (lt)	40+54+54
Boiler tankı kapasitesi (lt) / Boiler tank capacity (lt)	13+13
Yıkama sıcaklığı (°C) / Washing temperature (°C)	60-65
Durulama sıcaklığı (°C) / Rinsing temperature (°C)	80-85
Durulama su tüketimi (lt) / Rinsing water consumption (lt)	5-6
İç kabin yüksekliği (mm) / Internal cabinet height (mm)	480
Dinamik su giriş basıncı (bar) / Dynamic water input pressure (bar)	2-6
Dış ölçüler (WxDxH) (mm) / External dimensions (WxDxH) (mm)	3800 x 720 x 1800
Sepet ölçüleri (mm) / Basket dimensions (mm)	500 x 500 x 100
Toplam güç (kW) / Total power (kW)	70
Yıkama pompası gücü (kW) / Washing pump power (kW)	1,1+1,1
Net ağırlık (kg) / Net weight (kg)	450
Brüt ağırlık (kg) / Gross weight (kg)	480
Ön yıkama pompa gücü (kW) / Pre-washing pump power (kW)	1,1
Ön yıkama kazan ısıtıcı gücü (kW) / Pre-washing tank heater power (kW)	4
Yıkama kazan ısıtıcı gücü (kW) / Washing tank heater power (kW)	6+6
Boiler ısıtıcı gücü (kW) / Boiler heater power (kW)	16+16
Alt ve üst kurutma gücü (kW) / Lower and upper drying power (kW)	8+8

Genel Ölçüler / General Dimensions

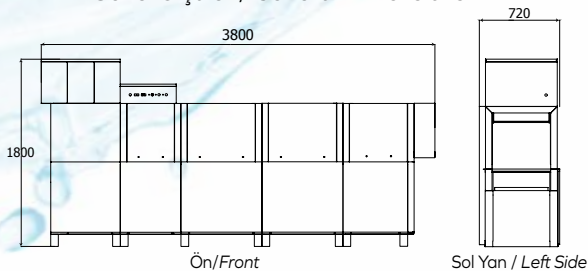

Opsiyonel Parçalar / Optional Parts

Çift hız kademeli Konveyör Sistemi / Conveyor System with dual-stage speed

Dijital Sıcaklık Göstergeleri / Digital Temperature Displays

Fiyat / Price € 340

Deterjan Pompası / Detergent Pump

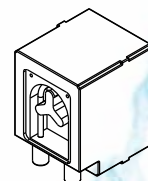

Fiyat / Price € 160

Parlatıcı Pompası / Rinse Aid Pump

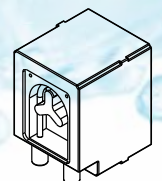

Fiyat / Price € 160

DW-6000 MODÜLER

22500 €



*Konveyörlü Tip
Bulaşık Yıkama Makinesi
Conveyor Type Dishwasher*



**6000 tabak/saat
yıkama kapasitesi
50 x 50 cm sepet**
**6000 dishes/hour
washing capacity
50 x 50 cm basket**



DW-6000 Aşamalar

- 1- Ön Yıkama Modülü
- 2- Yıkama Modülü 3 adet
- 3- Durulama Modülü
- 4- Kurutma Modülü (Alt ve üst kurutma)

DW-6000 Stages

- 1- Pre-washing Module
- 2- Washing Modules 3 pieces
- 3- Rinsing Module
- 4- Drying Module (Lower and upper drying)



Sağlamlaştırılmış konveyör taşıma hattı
Reinforced conveyor carrying line



Sağlamlaştırılmış konveyör taşıma hattı
Reinforced conveyor carrying line



Temizlenebilir yıkama kolları
Cleanable washing arms



Kullanıcı dostu kumanda ara yüzü
User-friendly control interface



Acil durdurma butonu
Emergency stop button

Genel Özellikler

- 18/10 304 AISI paslanmaz çelik gövde ve şase
- Yüksek kalitede paslanmaz çelik ısıtıcılar
- Kapağın kapatılmasıyla başlayan yıkama işlemi
- Dijital sıcaklık göstergeleri (opsiyonel)
- Avrupa üretimi motorlar
- Soğuk su ve sıcak su bağlantı imkanı
- Sıcak su bağlantısına dayanıklı komponentler sayesinde düşük elektrik tüketimi imkanı
- Bağımsız ön yıkama ve yıkama tankı
- Ön ısıtmalı boiler tank sistemi
- Emniyet termostatları
- Kullanıcı dostu kumanda arayüzü
- Yüksekliği ayarlanabilir ayaklar
- Güvenlik için acil durdurma butonu
- Ön yıkama, yıkama, durulama ve kurutma aşamaları
- Entegre tank filtresi
- Durulama, deterjan ve parlaticı pompası bağlanabilme imkanı (opsiyonel)

General Features

- 18/10 AISI 304 stainless steel construction
- High quality stainless steel heaters
- Cycle start at door closing
- Digital temperature display (optional)
- Motors are made in Europe
- Cold water and hot water connection possibility
- Low electricity consumption thanks to components resistant to hot water connection
- Individual pre-wash and wash tank
- Pre-heated boiler tank system
- Safety switches
- User-friendly control interface
- Height-adjustable legs
- Emergency stop button for safety
- Prewashing, washing, rinsing and drying stages
- Rinsing boost, detergent and rinse aid pump can be connected to chasis (optional)

TEKNİK ÖZELLİKLER / TECHNICAL SPECIFICATIONS

Model / Model	DW-6000
Güç girişi / Power input	380V/3/N ~ 50Hz
Su girişi / Water input	3x3/4"
Güç kaynağı / Power supply	Electric
Kumanda tipi / Command type	Analog
Yıkama periyodu (sn.) / Washing cycle (sec.)	Sürekli/Continuous
Yıkama kapasitesi (sepet/s) / Washing capacity (basket/h)	280
Yıkama yüksekliği (mm) / Washing clearance (mm)	480
Yıkama tankı kapasitesi (lt) / Washing tank capacity (lt)	40+54+54+54
Boiler tankı kapasitesi (lt) / Boiler tank capacity (lt)	13+13
Yıkama sıcaklığı (°C) / Washing temperature (°C)	60-65
Durulama sıcaklığı (°C) / Rinsing temperature (°C)	80-85
Durulama su tüketimi (lt) / Rinsing water consumption (lt)	05/06/21
İç kabin yüksekliği (mm) / Internal cabinet height (mm)	480
Dinamik su giriş basıncı (bar) / Dynamic water input pressure (bar)	2-6
Dış ölçüler (WxDxH) (mm) / External dimensions (WxDxH) (mm)	4600 x 720 x 1800
Sepet ölçüleri (mm) / Basket dimensions (mm)	500 x 500 x 100
Toplam güç (kW) / Total power (kW)	77,1
Yıkama pompası gücü (kW) / Washing pump power (kW)	1,1+1,1+1,1
Net ağırlık (kg) / Net weight (kg)	630
Brüt ağırlık (kg) / Gross weight (kg)	670
Ön yıkama pompa gücü (kW) / Pre-washing pump power (kW)	1,1
Ön yıkama kazan ısıtıcı gücü (kW) / Pre-washing tank heater power (kW)	4
Yıkama kazan ısıtıcı gücü (kW) / Washing tank heater power (kW)	6+6+6
Boiler ısıtıcı gücü (kW) / Boiler heater power (kW)	16+16
Alt ve üst kurutma gücü (kW) / Lower and upper drying power (kW)	8+8

Genel Ölçüler / General Dimensions

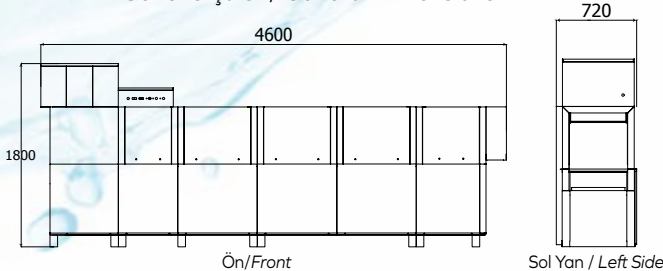

Opsiyonel Parçalar / Optional Parts

Çift hız kademeli Konveyör Sistemi / Conveyor System with dual-stage speed

Dijital Sıcaklık Göstergeleri / Digital Temperature Displays

Fiyat / Price € 340

Deterjan Pompası / Detergent Pump

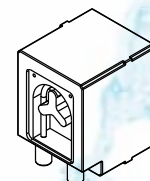

Fiyat / Price € 160

Parlaticı Pompası / Rinse Aid Pump

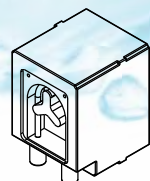

Fiyat / Price € 160

BS Serisi

240 €



Sepet Stantları
Basket Stands



Genel Özellikler

- Sepet standları makinenin yerden yükselmesini sağlar ve makinenin kullanımı kolaylaştırır.
- Drenaj pompası barındırmayan bulaşık makinelerinin boşaltma işleminin daha rahat gerçekleşmesini sağlar.
- Makineye ait sepetlerin muhafazasını ve ortamın düzenli olmasını sağlar.

General Features

- Basket stands allow the machine to rise from ground and makes using the machine simple.
- Basket stands help the drain process for non-drain pump connected machines.
- Provides housing baskets and provides the layout of the environment.

BS-500

DW-500
DW-500 ECO



500 x 500 x 100 ölçülerinde
iki (2) sepet taşıma kapasiteli

500 x 500 x 100 two (2)
baskets carrying capacity

BS-400

GW-640
GW-640 ECO



400 x 400 x 100 ölçülerinde
iki (2) sepet taşıma kapasiteli

400 x 400 x 100 two (2)
baskets carrying capacity

BS-350

GW-535
GW-535 ECO



350 x 350 x 150 ölçülerinde
iki (2) sepet taşıma kapasiteli

350 x 350 x 150 two (2)
baskets carrying capacity

Genel Ölçüler / General Dimensions

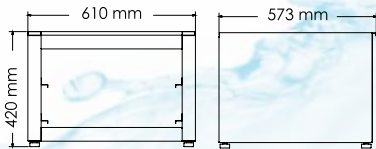

Ön/Front

Sol Yan / Left Side

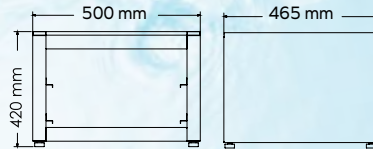

Ön/Front

Sol Yan / Left Side

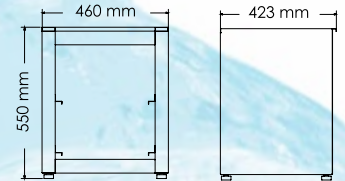

Ön/Front

Sol Yan / Left Side

BULAŞIK MAKİNESİ GİRİŞ TEZGAHI DISHWASHER ENTRY TABLE



BULAŞIK MAKİNESİ ÇIKIŞ TEZGAHI DISHWASHER EXIT TABLE



DW-1000 / DW-2000
DW-3000 / DW-4500 / DW-6000

İstenilen ölçülerde üretim
Production in required dimensions

SBY-300 SBY-600

Sebze Yıkama Makinesi
Continuous Vegetable
Washer Machine



19000 €

SBY-300

150 - 300 kg/saat yıkama kapasitesi
150 - 300 kg/hour washing capacity

22500 €

SBY-600

300 - 600 kg/saat yıkama kapasitesi
300 - 600 kg/hour washing capacity





Paslanmaz çelik kontrol kolları
Stainless steel control handles



Paslanmaz çelik çıkış tezgahı
Stainless steel exiting table



Konveyör boşaltma bandı
Unloader conveyor belt



Taşma önleyici sistem
Overflow protect system



Kullanıcı dostu kumanda ara yüzü
User-friendly control interface



Çıkış durulama hattı
Exiting Rinse Line



Pleksiglas üst kapaklar
Plexiglass covers



Basınç arttırıcı su fışkıyeleri
Water jets for enhanced pressure



Çöp delikli giriş tezgahı
Entering table with trash hole



Kolay temizlenebilir süzgeçler
Easy to clean filters



SBY-300 SBY-600

Sebze Yıkama Makinesi
Continuous Vegetable
Washer Machine



Genel Özellikler

- Tamamı AISI 304 18/10 kalite paslanmaz çelik malzemeden imal edilmiştir.
- Sağlamlaştırılmış paslanmaz çelik kumanda kollarına sahiptir.
- Gıdalar suyun türbülansı ile hem yıkanır hem de durulama bölümüne aktarılır.
- Boşaltma, konveyör bant ile sağlanır.
- Boşaltma hattı selenoid valf kontrollü durulama nozullarına sahiptir.
- Tüm vanalar ve yıkama aksesuarları paslanmaz çelik malzemeden üretilmiştir.
- Düşük voltaj içeren kumanda paneline sahiptir.

General Features

- AISI 304 18/10 grade stainless steel chasis construction
- Contain rugged stainless steel control handle
- Foods are washed by the turbulence of the water, at the same time transferred to the rinsing section
- Unloading conveyor belt.
- Unload line has solenoid valve for controlling rinsing nozzles
- All the valves and accessories made of stainless steel materials
- Contains low voltage on the control panels

Genel Ölçüler / General Dimensions

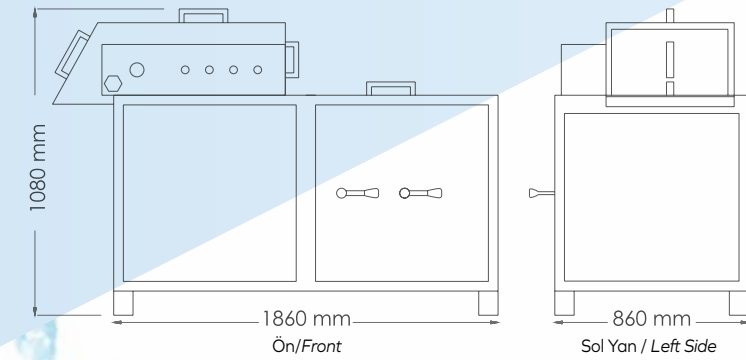

SBY-300

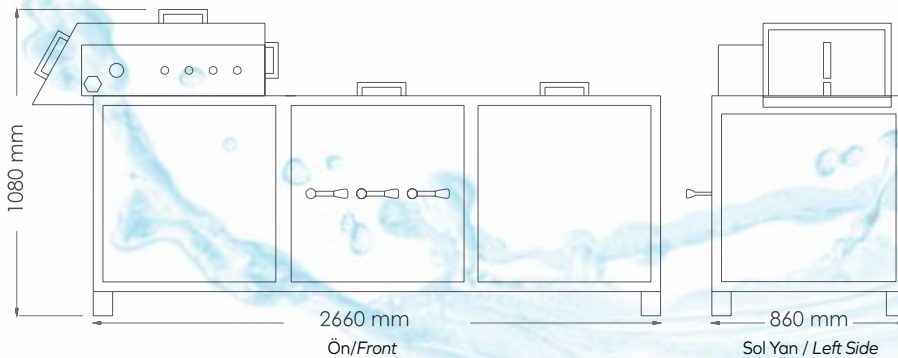

SBY-600

TEKNİK ÖZELLİKLER / TECHNICAL SPECIFICATIONS

Model / Model	SBY-300
Güç girişi / Power input	380V/3/N ~ 50Hz
Su girişi / Water input	3/4"
Su çıkışı / Water output	2"
Güç kaynağı / Power supply	Electric
Kumanda tipi / Command type	Analog
Ölçüler (WxDxH) (mm) / Dimensions (WxDxH) (mm)	860 x 1860 x 1080
Toplam güç (kW) / Total power (kW)	1,75
Kablo kesiti / Power input	5 x 2,5
Net ağırlık (kg) / Net weight (kg)	174
Brüt ağırlık (kg) / Gross weight (kg)	187
Tankı kapasitesi (lt) / Tank capacity (lt)	170
Hafif sebzeler için kapasite (kg/h) / Capacity for light vegetables (kg/h)	150
Ağır sebzeler için kapasite (kg/h) / Capacity for heavy vegetables (kg/h)	300

TEKNİK ÖZELLİKLER / TECHNICAL SPECIFICATIONS

Model / Model	SBY-600
Güç girişi / Power input	380V/3/N ~ 50Hz
Su girişi / Water input	3/4"
Su çıkışı / Water output	2"
Güç kaynağı / Power supply	Electric
Kumanda tipi / Command type	Analog
Ölçüler (WxDxH) (mm) / Dimensions (WxDxH) (mm)	860 x 2660 x 1080
Toplam güç (kW) / Total power (kW)	3,5
Kablo kesiti / Power input	5 x 2,5
Net ağırlık (kg) / Net weight (kg)	220
Brüt ağırlık (kg) / Gross weight (kg)	236
Tankı kapasitesi (lt) / Tank capacity (lt)	240
Hafif sebzeler için kapasite (kg/h) / Capacity for light vegetables (kg/h)	300
Ağır sebzeler için kapasite (kg/h) / Capacity for heavy vegetables (kg/h)	600

Opsiyonel Parçalar / Optional Parts

SCT-01 Çıkış Tezgahı
SCT-01 Exiting Table
SBY 300 / SBY 600

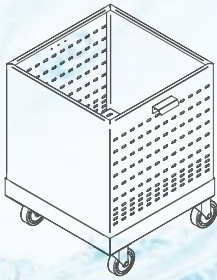

Fiyat / Price € 645

SGT-01 Giriş Tezgahı
SGT-01 Entering Table
SBY 300 / SBY 600

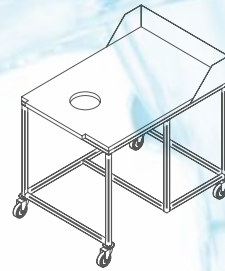

Fiyat / Price € 870

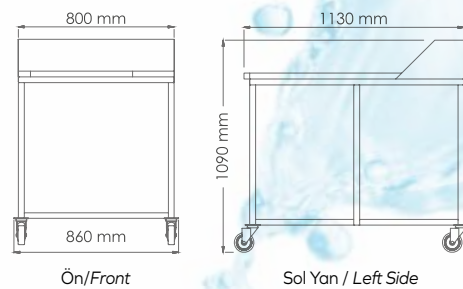
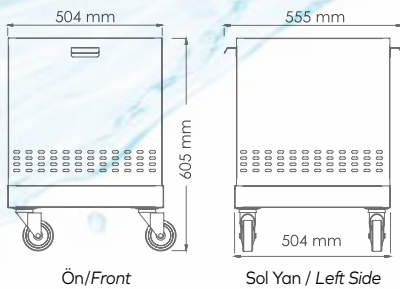

MKF

Patisserie



MKF-3

MKF-4

MKF-4P

MKF-6

MKF-10

MKF-4P DIGI

MKF-6 DIGI

MKF-10 DIGI

MKF-6G

MKF-10G

MKDF-10

MD-08

MAKSAN®



MKF Digi

P04P
160
20
29%



www.maksanmutlak.com.tr

MKF-3

1260 €



*Elektrik ısıtmalı Konveksiyonlu
Patisseri Fırını,
Electric Heated Convection
Bakery Oven*



**GN 2/3 x 3
tepsi kapasiteli**
**GN 2/3 x 3
tray capacity**



Aydınlatma lambalı pişirme kabini
Cooking cabinet with lighting lamp



Dayanıklı kapak sistemi
Durable door arm system



Paslanmaz çelik gövde ve şase
Stainless steel chassis construction



İki yönlü fan sistemi ile kusursuz pişirme
Perfect cooking with clockwise-anticlockwise fan system



Kullanıcı dostu kumanda arayüzü
User-friendly control interface

Genel Özellikler

- Paslanmaz çelik gövde ve şase
- Termostatik kontrol
- Yüksek verimli elektrikli ısıtma sistemi
- Kullanıcı tarafından sökülebilen çift camlı kapak sistemi ile temizlik imkanı
- Kapağın kapatılmasıyla başlayan pişirme döngüsü
- Güvenliği sağlayan emniyet termostatu
- Temizlik kolaylığı sunan fırın kabin tasarımı
- Kullanıcı dostu kumanda ara yüzü
- Aydınlatma lambalı pişirme kabini
- İki yönlü fan sistemi ile kusursuz pişirme
- Su bağlantısı ile gıdaların pişirilken nemlendirilmesi olanağı (opsiyonel)

General Features

- Stainless steel chasis construction
- Thermostatically controlled
- Highly efficient electric heating system
- Double-glazed removable door system allows to clean it by the user
- Cooking cycle start at door closing
- Safety thermostat provides security
- Interior design provides ease of cleaning
- User-friendly command interface
- Cooking cabinet with lighting lamb
- Perfect cooking with clockwise-anticlockwise fan system
- Water connection allows to cooking foods with humidity (optional)

TEKNİK ÖZELLİKLER / TECHNICAL SPECIFICATIONS

Model / Model	MKF-3
Güç girişi / Power input	220V/1/N ~ 50Hz
Su girişi / Water input	3/4"
Güç kaynağı / Power supply	Electric
Kumanda tipi / Command type	Analog
Zamanlayıcı (dk.) / Timer (min.)	120
Raf tipi / Shelve type	GN 2/3 / 25 x 35
Raf kapasitesi (ad) / Shelve capacity (qty)	3
Raf aralığı (mm) / Shelf space (mm)	70
Pişirme sıcaklığı (°C) / Cooking temperature (°C)	250
Dinamik su giriş basıncı (Bar) / Dynamic water input pressure (Bar)	2-6
Dış ölçüler (WxDxH) (mm) / External dimensions (WxDxH) (mm)	560 x 710 x 510
Fan gücü (kW) / Heating fan power (kW)	0,25
Konveksiyon gücü (kW) / Convection power (kW)	3
Toplam güç (kW) / Total power (kW)	3,25
Net ağırlık (kg) / Net weight (kg)	42
Brüt ağırlık (kg) / Gross weight (kg)	50

Genel Ölçüler / General Dimensions

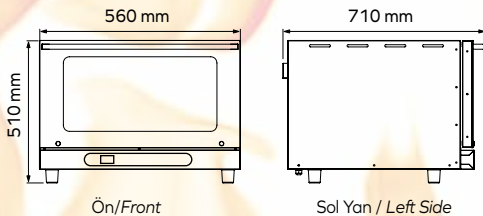

Opsiyonel Parçalar / Optional Parts

Nemlendirme Özelliği /
Humidification Feature

Taşıma Standı /
Oven Stand



Fiyat / Price € 60

FT-03
Fiyat / Price € 220

MKF-4

1830 €



*Elektrik ısıtmalı Konveksiyonlu
Patisseri Fırını,
Electric Heated Convection
Bakery Oven*



**600 x 400 mm x 4
tepsi kapasiteli**

**600 x 400 mm x 4
trays capacity**



Aydınlatma lambalı pişirme kabini
Cooking cabinet with lighting lamp



Kontrol Edilebilir baca çıkışı
The flue outlet is controllable



Paslanmaz çelik gövde ve şase
Stainless steel chassis construction



İki yönlü fan sistemi ile kusursuz pişirme
Perfect cooking with clockwise-anticlockwise fan system



Kullanıcı dostu kumanda arayüzü
User-friendly control interface

Genel Özellikler

- Paslanmaz çelik gövde ve şase
- Termostatik kontrol
- Yüksek verimli elektrikli ısıtma sistemi
- Kullanıcı tarafından sökülebilen çift camlı kapak sistemi ile temizlik imkanı
- Kapağın kapatılmasıyla başlayan pişirme döngüsü
- Güvenliği sağlayan emniyet termostati
- Temizlik kolaylığı sunan fırın kabin tasarımı
- Kullanıcı dostu kumanda ara yüzü
- Aydınlatma lambalı pişirme kabini
- Avrupa üretimi motor ve fanlar
- İki yönlü fan sistemi ile kusursuz pişirme
- Kokularını birbirine karıştırmadan farklı tipte gıdaları pişirebilme
- Su bağlantısı ile gıdaların pişirilirken nemlendirilmesi olanağı (opsiyonel)

General Features

- Stainless steel chasis construction
- Thermostatically controlled
- Highly efficient electric heating system
- Double-glazed removable door system allows to clean it by the user
- Cooking cycle start at door closing
- Safety thermostat provides security
- Interior design provides ease of cleaning
- User-friendly command interface
- Cooking cabinet with lighting lamb
- Motors and fans are manufactured in EU
- Perfect cooking with clockwise-anticlockwise fan system
- Cooking different kind of foods without mixing their smells
- Water connection allows to cooking foods with humidity (optional)

TEKNİK ÖZELLİKLER / TECHNICAL SPECIFICATIONS

Model / Model	MKF-4
Güç girişi / Power input	220V/1/N ~ 50Hz
Su girişi / Water input	3/4"
Güç kaynağı / Power supply	Electric
Kumanda tipi / Command type	Analog
Zamanlayıcı (dk.) / Timer (min.)	120
Raf tipi (mm) / Shelve type (mm)	600 x 400
Raf kapasitesi (ad) / Shelve capacity (qty)	4
Raf aralığı (mm) / Shelf space (mm)	70
Pişirme sıcaklığı (°C) / Cooking temperature (°C)	250
Dinamik su giriş basıncı (Bar) / Dynamic water input pressure (Bar)	2-6
Dış ölçüler (WxDxH) (mm) / External dimensions (WxDxH) (mm)	810 x 800 x 600
Fan gücü (kW) / Heating fan power (kW)	0,2
Konveksiyon gücü (kW) / Convection power (kW)	4,5
Toplam güç (kW) / Total power (kW)	4,7
Net ağırlık (kg) / Net weight (kg)	72
Brüt ağırlık (kg) / Gross weight (kg)	79

Genel Ölçüler / General Dimensions

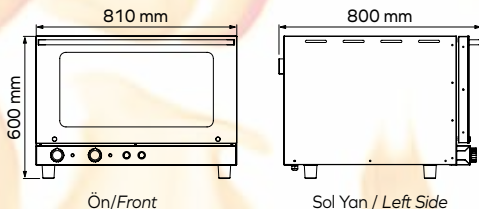

Opsiyonel Parçalar / Optional Parts

Nemlendirme Özelliği /
Humidification Feature



Fiyat / Price €60

600 x 400 mm Tepsi Rafı /
600 x 400 mm Tray Shelf

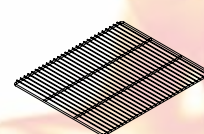

TR-02

Fiyat / Price €28

Taşıma Standı /
Oven Stand

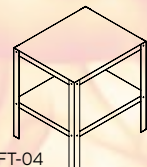

FT-04

Fiyat / Price €300

MKF-4P

1950 €



*Elektrik ısıtmalı Konveksiyonlu
Patisseri Fırını,
Electric Heated Convection
Bakery Oven*



**600 x 400 mm x 4
tepsi kapasiteli**

**600 x 400 mm x 4
trays capacity**



Aydınlatma lambalı pişirme kabini
Cooking cabinet with lighting lamp



Kontrol Edilebilir baca çıkışı
The flue outlet is controllable



Paslanmaz çelik gövde ve şase
Stainless steel chassis construction



İki yönlü fan sistemi ile kusursuz pişirme
Perfect cooking with clockwise-anticlockwise fan system



Kullanıcı dostu kumanda arayüzü
User-friendly control interface

Genel Özellikler

- Paslanmaz çelik gövde ve şase
- Termostatik kontrol
- Yüksek verimli elektrikli ısıtma sistemi
- Kullanıcı tarafından sökülebilen çift camlı kapak sistemi ile temizlik imkanı
- İsteğe bağlı GN 1/1 tepsi kiti ile gastronom tip tepsileri pişirme imkanı
- Kapağın kapatılmasıyla başlayan pişirme döngüsü
- Güvenliği sağlayan emniyet termostatu
- Temizlik kolaylığı sunan fırın kabin tasarımı
- Kullanıcı dostu kumanda ara yüzü
- Aydınlatma lambalı pişirme kabini
- Avrupa üretimi motor ve fanlar
- İki yönlü fan sistemi ile kusursuz pişirme
- Kontrol edilebilir baca çıkışı
- Kokularını birbirine karıştırmadan farklı tipte gıdaları pişirebilme
- Manuel nemlendirme özelliği

General Features

- Stainless steel chasis construction
- Thermostatically controlled
- Highly efficient electric heating system
- Double-glazed removable door system allows to clean it by the user
- GN 1/1 tray kit allows to cooking with gastronom trays upon request
- Cooking cycle start at door closing
- Safety thermostat provides security
- Interior design provides ease of cleaning
- User-friendly command interface
- Cooking cabinet with lighting lamb
- Motors and fans are manufactured in EU
- Perfect cooking with clockwise-anticlockwise fan system
- Cooking different kind of foods without mixing their smells
- The flue outlet is controllable
- Manuel humidity feature

TEKNİK ÖZELLİKLER / TECHNICAL SPECIFICATIONS

Model / Model	MKF-4P
Güç girişi / Power input	220V/1/N ~ 50Hz
Su girişi / Water input	3/4"
Güç kaynağı / Power supply	Electric
Kumanda tipi / Command type	Analog
Zamanlayıcı (dk.) / Timer (min.)	120
Raf tipi (mm) / Shelve type (mm)	600 x 400
Raf kapasitesi (ad) / Shelve capacity (qty)	4
Raf aralığı (mm) / Shelf space (mm)	70
Pişirme sıcaklığı (°C) / Cooking temperature (°C)	250
Dinamik su giriş basıncı (Bar) / Dynamic water input pressure (Bar)	2-6
Dış ölçüler (WxDxH) (mm) / External dimensions (WxDxH) (mm)	970 x 810 x 630
Fan gücü (kW) / Heating fan power (kW)	0,2
Konveksiyon gücü (kW) / Convection power (kW)	4,5
Toplam güç (kW) / Total power (kW)	4,7
Net ağırlık (kg) / Net weight (kg)	77
Brüt ağırlık (kg) / Gross weight (kg)	86

Genel Ölçüler / General Dimensions

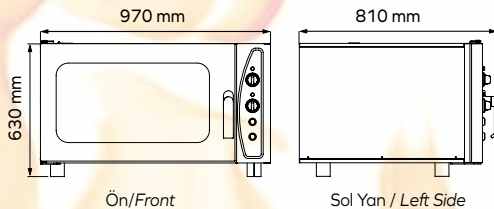

Opsiyonel Parçalar / Optional Parts

600 x 400 mm Tepsi Rafı /
600 x 400 mm Tray Shelf

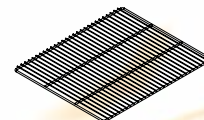

TR-02
Fiyat / Price € 28

Taşıma Standı /
Oven Stand

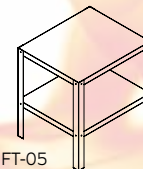

FT-05
Fiyat / Price € 360

GN 1/1 Tepsi Kiti /
GN 1/1 Tray Kit

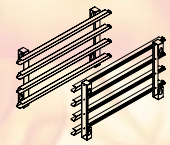

TK-03
Fiyat / Price € 84

MKF-6

3550 €



*Elektrik ısıtmalı Konveksiyonlu
Patisseri Fırını,
Electric Heated Convection
Bakery Oven*



**600 x 400 mm x 6
tepsi kapasiteli**
**600 x 400 mm x 6
trays capacity**



Aydınlatma lambalı pişirme kabini
Cooking cabinet with lighting lamb



Avrupa Üretim Motor ve Fanlar
Motor and Fans are manufactured in EU



Paslanmaz çelik gövde ve şase
Stainless steel chasis construction



İki yönlü fan sistemi ile kusursuz pişirme
Perfect cooking with clockwise- anticlockwise fan system



Dijital Sıcaklık Göstergeleri
Digital Temperature Displays

Genel Özellikler

- Paslanmaz çelik gövde ve şase
- Dijital göstergeli kontrol ünitesi
- Termostatik kontrol
- Yüksek verimli elektrikli ısıtma sistemi
- Kullanıcı tarafından sökülebilen çift camlı kapak sistemi ile temizlik imkanı
- İsteğe bağlı GN 1/1 tepsi kiti ile gastronom tip tepsileri pişirme imkanı
- Kapağın kapatılmasıyla başlayan pişirme döngüsü
- Güvenliği sağlayan emniyet termostatu
- Temizlik kolaylığı sunan fırın kabin tasarımı
- Kullanıcı dostu kumanda ara yüzü
- Aydınlatma lambalı pişirme kabini
- Avrupa üretimi motor ve fanlar
- İki yönlü fan sistemi ile kusursuz pişirme
- Kontrol edilebilir baca çıkışı
- Kokularını birbirine karıştırmadan farklı tipte gıdaları pişirebilme
- Manuel nemlendirme özelliği

General Features

- Stainless steel chasis construction
- Control unit with digital display
- Thermostatically controlled
- Highly efficient electric heating system
- Double-glazed removable door system allows to clean it by the user
- GN 1/1 tray kit allows to cooking with gastronom trays upon request
- Cooking cycle start at door closing
- Safety thermostat provides security
- Interior design provides ease of cleaning
- User-friendly command interface
- Cooking cabinet with lighting lamb
- Motors and fans are manufactured in EU
- Perfect cooking with clockwise-anticlockwise fan system
- The flue outlet is controllable
- Cooking different kind of foods without mixing their smells
- Manuel humidity feature

TEKNİK ÖZELLİKLER / TECHNICAL SPECIFICATIONS

Model / Model	MKF-6
Güç girişi / Power input	380V/3/N ~ 50Hz
Su girişi / Water input	3/4"
Güç kaynağı / Power supply	Electric
Kumanda tipi / Command type	Analog + Digital
Zamanlayıcı (dk.) / Timer (min.)	120
Raf tipi (mm) / Shelve type (mm)	600 x 400
Raf kapasitesi (ad) / Shelve capacity (qty)	6
Raf aralığı (mm) / Shelf space (mm)	80
Pişirme sıcaklığı (°C) / Cooking temperature (°C)	300
Dinamik su giriş basıncı (Bar) / Dynamic water input pressure (Bar)	2-6
Dış ölçüler (WxDxH) (mm) / External dimensions (WxDxH) (mm)	870 x 870 x 890
Fan gücü (kW) / Heating fan power (kW)	0,5
Konveksiyon gücü (kW) / Convection power (kW)	9
Toplam güç (kW) / Total power (kW)	9,5
Net ağırlık (kg) / Net weight (kg)	96
Brüt ağırlık (kg) / Gross weight (kg)	106

Genel Ölçüler / General Dimensions

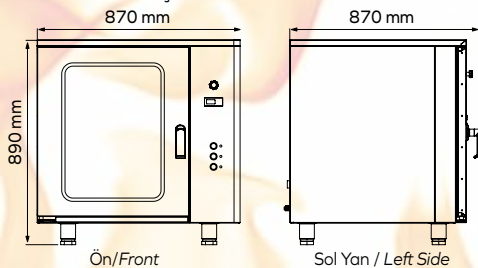

Opsiyonel Parçalar / Optional Parts

600 x 400 mm Tepsi Rafı /
600 x 400 mm Tray Shelf

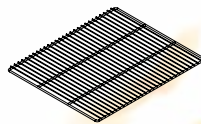

TR-02
Fiyat / Price € 28

Taşıma Standı /
Oven Stand

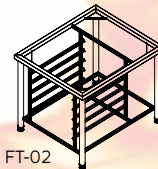

FT-02
Fiyat / Price € 480

GN 1/1 Tepsi Kiti /
GN 1/1 Tray Kit

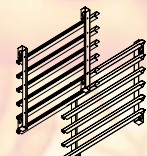

TK-01
Fiyat / Price € 104

MKF-10

4750 €



*Elektrik ısıtmalı Konveksiyonlu
Patisseri Fırını,
Electric Heated Convection
Bakery Oven*



**600 x 400 mm x 10
tepsi kapasiteli**
**600 x 400 mm x 10
trays capacity**



Aydınlatma lambalı pişirme kabini
Cooking cabinet with lighting lamb



Avrupa Üretim Motor ve Fanlar
Motor and Fans are manufactured in EU



Paslanmaz çelik gövde ve şase
Stainless steel chasis construction



İki yönlü fan sistemi ile kusursuz pişirme
Perfect cooking with clockwise-anticlockwise fan system



Dijital Sıcaklık Göstergeleri
Digital Temperature Displays

Genel Özellikler

- Paslanmaz çelik gövde ve şase
- Dijital göstergeli kontrol ünitesi
- Termostatik kontrol
- Yüksek verimli elektrikli ısıtma sistemi
- Kullanıcı tarafından sökülebilen çift camlı kapak sistemi ile temizlik imkanı
- İsteğe bağlı GN 1/1 tepsi kiti ile gastronom tip tepsileri pişirme imkanı
- Kapağın kapatılmasıyla başlayan pişirme döngüsü
- Güvenliği sağlayan emniyet termostatu
- Temizlik kolaylığı sunan fırın kabin tasarımı
- Kullanıcı dostu kumanda ara yüzü
- Aydınlatma lambalı pişirme kabini
- Avrupa üretimi motor ve fanlar
- İki yönlü fan sistemi ile kusursuz pişirme
- Kokularını birbirine karıştırmadan farklı tipte gıdaları pişirebilme
- Manuel nemlendirme özelliği

General Features

- Stainless steel chasis construction
- Control unit with digital display
- Thermostatically controlled
- Highly efficient electric heating system
- Double-glazed removable door system allows to clean it by the user
- GN 1/1 tray kit allows to cooking with gastronom trays upon request
- Cooking cycle start at door closing
- Safety thermostat provides security
- Interior design provides ease of cleaning
- User-friendly command interface
- Cooking cabinet with lighting lamb
- Motors and fans are manufactured in EU
- Perfect cooking with clockwise-anticlockwise fan system
- Cooking different kind of foods without mixing their smells
- Manuel humidity feature

TEKNİK ÖZELLİKLER / TECHNICAL SPECIFICATIONS

Model / Model	MKF-10
Güç girişi / Power input	380V/3/N ~ 50Hz
Su girişi / Water input	3/4"
Güç kaynağı / Power supply	Electric
Kumanda tipi / Command type	Analog + Digital
Zamanlayıcı (dk.) / Timer (min.)	120
Raf tipi (mm) / Shelve type (mm)	600 x 400
Raf kapasitesi (ad) / Shelve capacity (qty)	10
Raf aralığı (mm) / Shelf space (mm)	80
Pişirme sıcaklığı (°C) / Cooking temperature (°C)	300
Dinamik su giriş basıncı (Bar) / Dynamic water input pressure (Bar)	2-6
Dış ölçüler (WxDxH) (mm) / External dimensions (WxDxH) (mm)	940 x 870 x 1210
Fan gücü (kW) / Heating fan power (kW)	0,5
Konveksiyon gücü (kW) / Convection power (kW)	13,5
Toplam güç (kW) / Total power (kW)	14
Net ağırlık (kg) / Net weight (kg)	130
Brüt ağırlık (kg) / Gross weight (kg)	140

Genel Ölçüler / General Dimensions

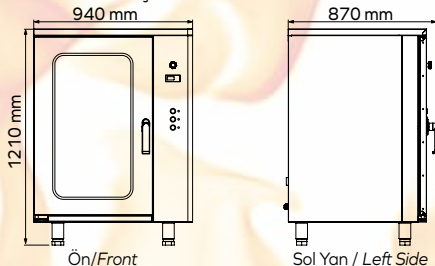

Opsiyonel Parçalar / Optional Parts

600 x 400 mm Tepsi Rafı /
600 x 400 mm Tray Shelf

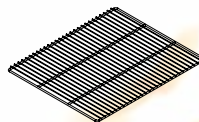

TR-02
Fiyat / Price € 28

Taşıma Standı /
Oven Stand

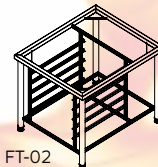

FT-02
Fiyat / Price € 480

GN 1/1 Tepsi Kiti /
GN 1/1 Tray Kit

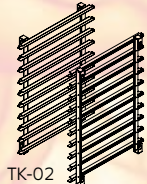

TK-02
Fiyat / Price € 172

MKF-4P DIGI

2590 €

*Elektrik ısıtmalı Konveksiyonlu
Patisseri Fırını,
Electric Heated Convection
Bakery Oven*



600 x 400 mm x 4
tepsi kapasiteli

600 x 400 mm x 4
trays capacity



Aydınlatma lambalı pişirme kabini
Cooking cabinet with lighting lamp



Kontrol Edilebilir baca çıkışı
The flue outlet is controllable



Paslanmaz çelik gövde ve şase
Stainless steel chassis construction



İki yönlü fan sistemi ile kusursuz pişirme
Perfect cooking with clockwise- anticlockwise fan system



LCD Panel
LCD Display

Genel Özellikler

- İki yönlü fan sistemi ile kusursuz pişirme
- LCD panel
- 6 kademe ayarlanabilir fan hızı
- Dokunmatik butonlar
- Analog fırınlara göre %50 enerji tasarrufu
- Paslanmaz çelik gövde ve şase
- Dijital göstergeli kontrol ünitesi
- Ekran üzerinden ayarlanabilir manuel veya otomatik buhar verme
- Ayarlanan pişirme derecesine göre otomatik ön ısıtma
- Yüzdesel otomatik nemlendirme
- %1 hassasiyetle ısı kontrolü
- 1 manuel program olmak üzere toplam 50 program hafızası
- 1 program içerisine 3 aşamalı alt program yazabilme
- Yüksek verimli elektrikli ısıtma sistemi
- Kullanıcı tarafından sökülebilen çift camlı kapak sistemi ile temizlik imkanı
- İsteğe bağlı GN 1/1 tepsi kiti ile gastronom tip tepsileri pişirme imkanı
- Kapağın kapatılmasıyla başlayan pişirme döngüsü
- Ön bölümde yağ toplama haznesi
- Güvenliği sağlayan emniyet termostatu
- Temizlik kolaylığı sunan fırın kabin tasarımı
- Kokularını birbirine karıştırmadan farklı tipte gıdaları pişirebilme
- Avrupa üretimi motor ve fanlar

General Features

- Perfect cooking with clockwise-anticlockwise fan system
- LCD displays
- Adjustable 6 fan speed
- Touch buttons
- 50% energy saving compared to analogic ovens
- Stainless steel chasis construction
- Control unit with digital display
- Manual or automatic steam adjustable on the display
- Automatic preheating according to the set degree of cooking
- Percentage adjustable automatic steam
- Temperature control with 1% precision
- Total 50 program memory, including 1 manual program
- Writing a 3-stage sub-program into a program
- Highly efficient electric heating system
- Double-glazed removable door system allows to clean it by the user
- GN 1/1 tray kit allows to cooking with gastronom trays upon request
- Cooking cycle start at door closing
- The front section contains the oil collection chamber.
- Safety thermostat provides security
- Interior design provides ease of cleaning
- Cooking different kind of foods without mixing their smells
- Motors and fans are manufactured in EU

TEKNİK ÖZELLİKLER / TECHNICAL SPECIFICATIONS

Model / Model	MKF-4P DIGI
Güç girişi / Power input	220V/1/N ~ 50Hz
Su girişi / Water input	3/4"
Güç kaynağı / Power supply	Electric
Kumanda tipi / Command type	Dijital
Zamanlayıcı (dk.) / Timer (min.)	120
Raf tipi (mm) / Shelve type (mm)	600 x 400
Raf kapasitesi (ad) / Shelve capacity (qty)	4
Raf aralığı (mm) / Shelf space (mm)	70
Pişirme sıcaklığı (°C) / Cooking temperature (°C)	250
Dinamik su giriş basıncı (Bar) / Dynamic water input pressure (Bar)	2-6
Dış ölçüler (WxDxH) (mm) / External dimensions (WxDxH) (mm)	970 x 810 x 630
Fan gücü (kW) / Heating fan power (kW)	0,2
Konveksiyon gücü (kW) / Convection power (kW)	4,5
Toplam güç (kW) / Total power (kW)	4,7
Net ağırlık (kg) / Net weight (kg)	77
Brüt ağırlık (kg) / Gross weight (kg)	86

Genel Ölçüler / General Dimensions

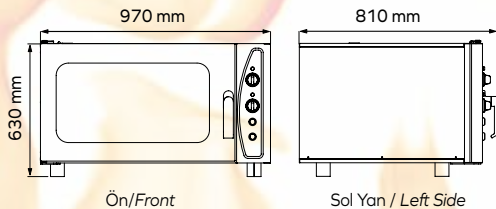

Opsiyonel Parçalar / Optional Parts

600 x 400 mm Tepsi Rafi /
600 x 400 mm Tray Shelf

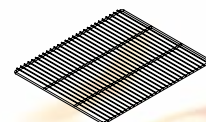

TR-02
Fiyat / Price € 28

Taşıma Standı /
Oven Stand



FT-05
Fiyat / Price € 360

GN 1/1 Tepsi Kiti /
GN 1/1 Tray Kit

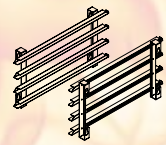

TK-03
Fiyat / Price € 84

MKF-6 DIGI

4190 €



*Elektrik ısıtmalı Konveksiyonlu
Patisseri Fırını,
Electric Heated Convection
Bakery Oven*



**600 x 400 mm x 6
tepsi kapasiteli**
**600 x 400 mm x 6
trays capacity**



Aydınlatma lambalı pişirme kabini
Cooking cabinet with lighting lamb



Avrupa Üretim Motor ve Fanlar
Motor and Fans are manufactured in EU



Paslanmaz çelik gövde ve şase
Stainless steel chassis construction



İki yönlü fan sistemi ile kusursuz pişirme
Perfect cooking with clockwise-anticlockwise fan system



LCD Panel
LCD Display

Genel Özellikler

- İki yönlü fan sistemi ile kusursuz pişirme
- LCD panel
- 6 kademe ayarlanabilir fan hızı
- Dokunmatik butonlar
- Analog fırınlara göre %50 enerji tasarrufu
- Paslanmaz çelik gövde ve şase
- Dijital göstergeli kontrol ünitesi
- Ekran üzerinden ayarlanabilir manuel veya otomatik buhar verme
- Ayarlanan pişirme derecesine göre otomatik ön ısıtma
- Yüzdesele otomatik nemlendirme
- %1 hassasiyetle ısı kontrolü
- 1 manuel program olmak üzere toplam 50 program hafızası
- 1 program içerisine 3 aşamalı alt program yazabilme
- Yüksek verimli elektrikli ısıtma sistemi
- Kullanıcı tarafından sökülebilen çift camlı kapak sistemi ile temizlik imkanı
- İsteğe bağlı GN 1/1 tepsi kiti ile gastronom tip tepsileri pişirme imkanı
- Kapağın kapatılmasıyla başlayan pişirme döngüsü
- Ön bölümde yağ toplama haznesi
- Güvenliği sağlayan emniyet termostatu
- Temizlik kolaylığı sunan fırın kabin tasarımı
- Kokularını birbirine karıştırmadan farklı tipte gıdaları pişirebilme
- Avrupa üretimi motor ve fanlar

General Features

- Perfect cooking with clockwise-anticlockwise fan system
- LCD displays
- Adjustable 6 fan speed
- Touch buttons
- 50% energy saving compared to analogic ovens
- Stainless steel chasis construction
- Control unit with digital display
- Manual or automatic steam adjustable on the display
- Automatic preheating according to the set degree of cooking
- Percentage adjustable automatic steam
- Temperature control with 1% precision
- Total 50 program memory, including 1 manual program
- Writing a 3-stage sub-program into a program
- Highly efficient electric heating system
- Double-glazed removable door system allows to clean it by the user
- GN 1/1 tray kit allows to cooking with gastronom trays upon request
- Cooking cycle start at door closing
- The front section contains the oil collection chamber.
- Safety thermostat provides security
- Interior design provides ease of cleaning
- Cooking different kind of foods without mixing their smells
- Motors and fans are manufactured in EU

TEKNİK ÖZELLİKLER / TECHNICAL SPECIFICATIONS

Model / Model	MKF-6 DIGI
Güç girişi / Power input	380V/3/N ~ 50Hz
Su girişi / Water input	3/4"
Güç kaynağı / Power supply	Electric
Kumanda tipi / Command type	Digital
Zamanlayıcı (dk.) / Timer (min.)	120
Raf tipi (mm) / Shelve type (mm)	600 x 400
Raf kapasitesi (ad) / Shelve capacity (qty)	6
Raf aralığı (mm) / Shelf space (mm)	80
Pişirme sıcaklığı (°C) / Cooking temperature (°C)	300
Dinamik su giriş basıncı (Bar) / Dynamic water input pressure (Bar)	2-6
Dış ölçüler (WxDxH) (mm) / External dimensions (WxDxH) (mm)	870 x 870 x 890
Fan gücü (kW) / Heating fan power (kW)	0,5
Konveksiyon gücü (kW) / Convection power (kW)	9
Toplam güç (kW) / Total power (kW)	9,5
Net ağırlık (kg) / Net weight (kg)	96
Brüt ağırlık (kg) / Gross weight (kg)	106

Genel Ölçüler / General Dimensions

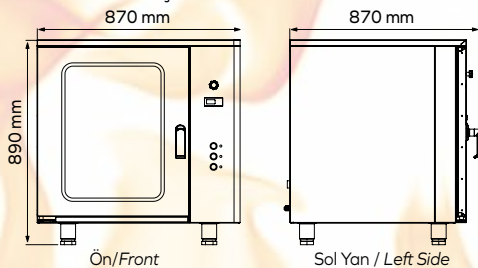

Opsiyonel Parçalar / Optional Parts

600 x 400 mm Tepsi Rafı /
600 x 400 mm Tray Shelf

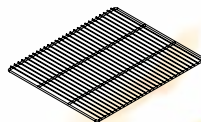

TR-02
Fiyat / Price € 28

Taşıma Standı /
Oven Stand

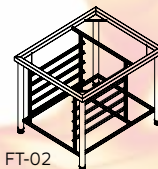

FT-02
Fiyat / Price € 480

GN 1/1 Tepsi Kiti /
GN 1/1 Tray Kit

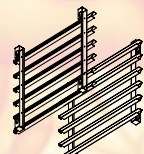

TK-01
Fiyat / Price € 104

MKF-10 DIGI

5390 €



*Elektrik ısıtmalı Konveksiyonlu
Patisseri Fırını,
Electric Heated Convection
Bakery Oven*



**600 x 400 mm x 10
tepsi kapasiteli**
**600 x 400 mm x 10
trays capacity**



Aydınlatma lambalı pişirme kabini
Cooking cabinet with lighting lamp



Avrupa Üretim Motor ve Fanlar
Motor and Fans are manufactured in EU



Paslanmaz çelik gövde ve şase
Stainless steel chassis construction



İki yönlü fan sistemi ile kusursuz pişirme
Perfect cooking with clockwise-anticlockwise fan system



LCD Panel
LCD Display

Genel Özellikler

- İki yönlü fan sistemi ile kusursuz pişirme
- LCD panel
- 6 kademe ayarlanabilir fan hızı
- Dokunmatik butonlar
- Analog fırınlara göre %50 enerji tasarrufu
- Paslanmaz çelik gövde ve şase
- Dijital göstergeli kontrol ünitesi
- Ekran üzerinden ayarlanabilir manuel veya otomatik buhar verme
- Ayarlanan pişirme derecesine göre otomatik ön ısıtma
- Yüzdesele otomatik nemlendirme
- %1 hassasiyetle ısı kontrolü
- 1 manuel program olmak üzere toplam 50 program hafızası
- 1 program içerisine 3 aşamalı alt program yazabilme
- Yüksek verimli elektrikli ısıtma sistemi
- Kullanıcı tarafından sökülebilen çift camlı kapak sistemi ile temizlik imkanı
- İsteğe bağlı GN 1/1 tepsi kiti ile gastronom tip tepsileri pişirme imkanı
- Kapağın kapatılmasıyla başlayan pişirme döngüsü
- Ön bölümde yağ toplama haznesi
- Güvenliği sağlayan emniyet termostatu
- Temizlik kolaylığı sunan fırın kabin tasarımı
- Kokularını birbirine karıştırmadan farklı tipte gıdaları pişirebilme
- Avrupa üretimi motor ve fanlar

General Features

- Perfect cooking with clockwise-anticlockwise fan system
- LCD displays
- Adjustable 6 fan speed
- Touch buttons
- 50% energy saving compared to analogic ovens
- Stainless steel chasis construction
- Control unit with digital display
- Manual or automatic steam adjustable on the display
- Automatic preheating according to the set degree of cooking
- Percentage adjustable automatic steam
- Temperature control with 1% precision
- Total 50 program memory, including 1 manual program
- Writing a 3-stage sub-program into a program
- Highly efficient electric heating system
- Double-glazed removable door system allows to clean it by the user
- GN 1/1 tray kit allows to cooking with gastronom trays upon request
- Cooking cycle start at door closing
- The front section contains the oil collection chamber.
- Safety thermostat provides security
- Interior design provides ease of cleaning
- Cooking different kind of foods without mixing their smells
- Motors and fans are manufactured in EU

TEKNİK ÖZELLİKLER / TECHNICAL SPECIFICATIONS

Model / Model	MKF-10 DIGI
Güç girişi / Power input	380V/3/N ~ 50Hz
Su girişi / Water input	3/4"
Güç kaynağı / Power supply	Electric
Kumanda tipi / Command type	Digital
Zamanlayıcı (dk.) / Timer (min.)	120
Raf tipi (mm) / Shelve type (mm)	600 x 400
Raf kapasitesi (ad) / Shelve capacity (qty)	10
Raf aralığı (mm) / Shelf space (mm)	80
Pişirme sıcaklığı (°C) / Cooking temperature (°C)	300
Dinamik su giriş basıncı (Bar) / Dynamic water input pressure (Bar)	2-6
Dış ölçüler (WxDxH) (mm) / External dimensions (WxDxH) (mm)	940 x 870 x 1210
Fan gücü (kW) / Heating fan power (kW)	0,5
Konveksiyon gücü (kW) / Convection power (kW)	13,5
Toplam güç (kW) / Total power (kW)	14
Net ağırlık (kg) / Net weight (kg)	130
Brüt ağırlık (kg) / Gross weight (kg)	140

Genel Ölçüler / General Dimensions

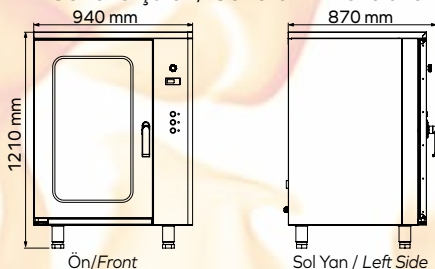

Opsiyonel Parçalar / Optional Parts

600 x 400 mm Tepsi Rafı /
600 x 400 mm Tray Shelf

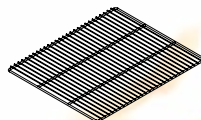

TR-02
Fiyat / Price € 28

Taşıma Standı /
Oven Stand

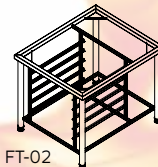

FT-02
Fiyat / Price € 480

GN 1/1 Tepsi Kiti /
GN 1/1 Tray Kit

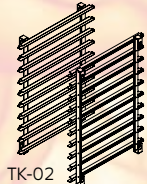

TK-02
Fiyat / Price € 172

MKF-6G

4020 €



*Gaz ısıtmalı Konveksiyonlu
Patisseri Fırını,
Gas Heated Convection
Bakery Oven*



**600 x 400 mm x 6
tepsi kapasiteli**
**600 x 400 mm x 6
trays capacity**



Aydınlatma lambalı pişirme kabini
Cooking cabinet with lighting lamp



Dayanıklı kapak sistemi
Durable door arm system



Paslanmaz çelik gövde ve şase
Stainless steel chassis construction



Avrupa Üretim Motor ve Fanlar
Motor and Fans are manufactured in EU



Kullanıcı dostu kumanda ara yüzü
User-friendly control interface

Genel Özellikler

- Paslanmaz çelik gövde ve şase
- Termostatik kontrol
- Yüksek verimli gaz ısıtma sistemi
- Kullanıcı tarafından sökülebilen çift camlı kapak sistemi ile temizlik imkanı
- İsteğe bağlı GN 1/1 tepsi kiti ile gastronom tip tepsileri pişirme imkanı
- Kapağın kapatılmasıyla başlayan pişirme döngüsü
- Güvenliği sağlayan emniyet termostati
- Temizlik kolaylığı sunan fırın kabin tasarımı
- Kullanıcı dostu kumanda ara yüzü
- Aydınlatma lambalı pişirme kabini
- Avrupa üretimi motor ve fanlar
- Kontrol edilebilir baca çıkışı
- Kokularını birbirine karıştırmadan farklı tipte gıdaları pişirebilme
- Fonksiyonel otomatik nemlendirmeli pişirme programları
- İsteğe bağlı NG veya LPG'ye uyumlu üretim

General Features

- Stainless steel chasis construction
- Thermostatically controlled
- Highly efficient gas heating system
- Double-glazed removable door system allows to clean it by the user
- GN 1/1 tray kit allows to cooking with gastronom trays upon request
- Cooking cycle start at door closing
- Safety thermostat provides security
- Interior design provides ease of cleaning
- User-friendly command interface
- Cooking cabinet with lighting lamb
- Motors and fans are manufactured in EU
- The flue outlet is controllable
- Cooking different kind of foods without mixing their smells
- Functional automatic cooking programs with humidification
- Production compatible with NG or LPG upon request

TEKNİK ÖZELLİKLER / TECHNICAL SPECIFICATIONS

Model / Model	MKF-6G
Güç girişi / Power input	380V/3/N ~ 50Hz
Su girişi / Water input	3/4"
Güç kaynağı / Power supply	Gas
Kumanda tipi / Command type	Analog
Zamanlayıcı (dk.) / Timer (min.)	120
Raf tipi (mm) / Shelve type (mm)	600 x 400
Raf kapasitesi (ad) / Shelve capacity (qty)	6
Raf aralığı (mm) / Shelf space (mm)	80
Pişirme sıcaklığı (°C) / Cooking temperature (°C)	300
Dinamik su giriş basıncı (Bar) / Dynamic water input pressure (Bar)	2-6
Dış ölçüler (WxDxH) (mm) / External dimensions (WxDxH) (mm)	860 x 1280 x 990
Fan gücü (kW) / Heating fan power (kW)	0,75
Konveksiyon gücü (kW) / Convection power (kW)	10
Toplam güç (kW) / Total power (kW)	1
Kablo kesiti (mm ²) / Cable cross-section (mm ²)	5x2,5
Net ağırlık (kg) / Net weight (kg)	165
Brüt ağırlık (kg) / Gross weight (kg)	180

Genel Ölçüler / General Dimensions

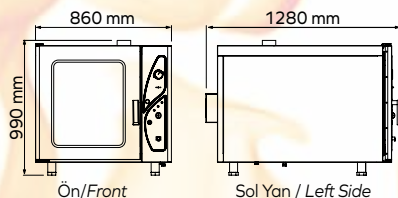

Opsiyonel Parçalar / Optional Parts

600 x 400 mm Tepsi Rafı /
600 x 400 mm Tray Shelf

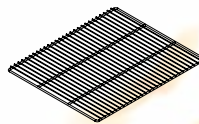

TR-02
Fiyat / Price € 28

Taşıma Standı /
Oven Stand

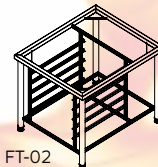

FT-02
Fiyat / Price € 480

GN 1/1 Tepsi Kiti /
GN 1/1 Tray Kit

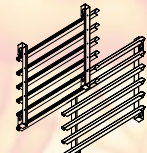

TK-01
Fiyat / Price € 104

MKF-10G

5240 €



*Gaz ısıtmalı Konveksiyonlu
Patisseri Fırını,
Gas Heated Convection
Bakery Oven*



**600 x 400 mm x 10
tepsi kapasiteli**
**600 x 400 mm x 10
trays capacity**



Aydınlatma lambalı pişirme kabini
Cooking cabinet with lighting lamp



Kontrol Edilebilir baca çıkışı
The flue outlet is controllable



Paslanmaz çelik gövde ve şase
Stainless steel chassis construction



Avrupa Üretim Motor ve Fanlar
Motor and Fans are manufactured in EU



Kullanıcı dostu kumanda ara yüzü
User-friendly control interface

Genel Özellikler

- Paslanmaz çelik gövde ve şase
- Termostatik kontrol
- Yüksek verimli gaz ısıtma sistemi
- Kullanıcı tarafından sökülebilen çift camlı kapak sistemi ile temizlik imkanı
- İsteğe bağlı GN 1/1 tepsi kiti ile gastronom tip tepsileri pişirme imkanı
- Kapağın kapatılmasıyla başlayan pişirme döngüsü
- Güvenliği sağlayan emniyet termostadı
- Temizlik kolaylığı sunan fırın kabin tasarımı
- Kullanıcı dostu kumanda ara yüzü
- Aydınlatma lambalı pişirme kabini
- Avrupa üretimi motor ve fanlar
- Kontrol edilebilir baca çıkışı
- Kokularını birbirine karıştırmadan farklı tipte gıdaları pişirebilme
- Fonksiyonel otomatik nemlendirmeli pişirme programları
- İsteğe bağlı NG veya LPG'ye uyumlu üretim

General Features

- Stainless steel chasis construction
- Thermostatically controlled
- Highly efficient gas heating system
- Double-glazed removable door system allows to clean it by the user
- GN 1/1 tray kit allows to cooking with gastronom trays upon request
- Cooking cycle start at door closing
- Safety thermostat provides security
- Interior design provides ease of cleaning
- User-friendly command interface
- Cooking cabinet with lighting lamb
- Motors and fans are manufactured in EU
- The flue outlet is controllable
- Cooking different kind of foods without mixing their smells
- Functional automatic cooking programs with humidification
- Production compatible with NG or LPG upon request

TEKNİK ÖZELLİKLER / TECHNICAL SPECIFICATIONS

Model / Model	MKF-10G
Güç girişi / Power input	380V/3/N ~ 50Hz
Su girişi / Water input	3/4"
Güç kaynağı / Power supply	Gas
Gaz girişi / Gas input	1/2"
Kumanda tipi / Command type	Analog
Zamanlayıcı (dk.) / Timer (min.)	120
Raf tipi (mm) / Shelve type (mm)	600 x 400
Raf kapasitesi (ad) / Shelve capacity (qty)	10
Raf aralığı (mm) / Shelf space (mm)	80
Pişirme sıcaklığı (°C) / Cooking temperature (°C)	300
Dinamik su giriş basıncı (Bar) / Dynamic water input pressure (Bar)	2-6
Dış ölçüler (WxDxH) (mm) / External dimensions (WxDxH) (mm)	860 x 1280 x 1190
Fan gücü (kW) / Heating fan power (kW)	0,75
Konveksiyon gücü (kW) / Convection power (kW)	16
Toplam güç (kW) / Total power (kW)	1
Toplam gaz sarfiyatı / Total gas consumption	1.8 m ³ /h G20 (NG) - 1.4 kg/h G30 LPG
Kablo kesiti (mm ²) / Cable cross-section (mm ²)	5x2,5
Net ağırlık (kg) / Net weight (kg)	180
Brüt ağırlık (kg) / Gross weight (kg)	195

Genel Ölçüler / General Dimensions

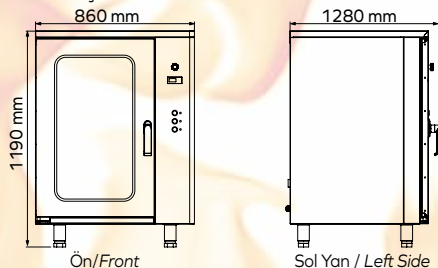

Opsiyonel Parçalar / Optional Parts

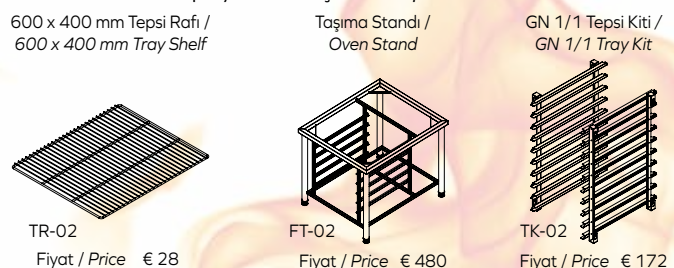

MKDF-10

11000 €



*Elektrik ısıtımali Konveksiyonlu
Dönerli Patisseriesi Fırını,
Electric Heated Convection
Rotary Bakery Oven*



**600 x 400 mm x 10 tepsi
kapasiteli**

**600 x 400 mm x 10
trays capacity**



Aydınlatma lambalı pişirme kabini
Cooking cabinet with lighting lamp



Avrupa Üretim Motor ve Fanlar
Motor and Fans are manufactured in EU



Paslanmaz çelik gövde ve şase
Stainless steel chassis construction



İki yönlü fan sistemi ile kusursuz pişirme
Perfect cooking with clockwise-anticlockwise fan system



Kullanıcı dostu kumanda ara yüzü
User-friendly control interface

Genel Özellikler

- Paslanmaz çelik gövde ve şase
- Eşit pişirme sağlayan döner tepsi sistemi
- Termostatik kontrol
- Tekerlekleriyle kolay yer değiştirme
- Mayalama kabiniyle kombine etme imkanı
- Kapı açıldığında otomatik boşaltma pozisyonu
- Yüksek verimli elektrikli ısıtma sistemi
- Kullanıcı tarafından sökülebilen çift camlı kapak sistemi ile temizlik imkanı
- Kapağın kapatılmasıyla başlayan pişirme döngüsü
- Davlumbaz mevcuttur
- Güvenliği sağlayan emniyet termostati
- Temizlik kolaylığı sunan fırın kabin tasarımı
- Kullanıcı dostu kumanda arç yüzü
- Aydınlatma lambalı pişirme kabini
- Avrupa üretimi motor ve fanlar
- İki yönlü fan sistemi ile kusursuz pişirme
- Manuel nemlendirme özelliği

General Features

- Stainless steel chasis construction
- Rotating tray system that ensures even cooking
- Thermostatically controlled
- Mobility with wheels
- Possibility to combine with the fermentation cabinet
- Automatic unloading position when the door is opened
- Highly efficient electric heating system
- Double-glazed removable door system allows to clean it by the user
- Cooking cycle start at door closing
- Hood included
- Safety thermostat provides security
- Interior design provides ease of cleaning
- User-friendly command interface
- Cooking cabinet with lighting lamb
- Motors and fans are manufactured in EU
- Perfect cooking with clockwise-anticlockwise fan system
- Manuel humidity feature

TEKNİK ÖZELLİKLER / TECHNICAL SPECIFICATIONS

Model / Model	MKDF-10
Güç girişi / Power input	380V/3/N ~ 50Hz
Su girişi / Water input	3/4"
Güç kaynağı / Power supply	Electric
Kumanda tipi / Command type	Analog
Zamanlayıcı (dk.) / Timer (min.)	Analog
Raf tipi (mm) / Shelve type (mm)	600 x 400
Raf kapasitesi (ad) / Shelve capacity (qty)	10
Raf aralığı (mm) / Shelf space (mm)	80
Piştirme sıcaklığı (°C) / Cooking temperature (°C)	300
Dinamik su giriş basıncı (Bar) / Dynamic water input pressure (Bar)	2-6
Dış ölçüler (WxDxH) (mm) / External dimensions (WxDxH) (mm)	1100 x 1470 x 1600
Fan gücü (kW) / Heating fan power (kW)	1
Konveksiyon gücü (kW) / Convection power (kW)	27
Toplam güç (kW) / Total power (kW)	28
Net ağırlık (kg) / Net weight (kg)	275
Brüt ağırlık (kg) / Gross weight (kg)	290

Genel Ölçüler / General Dimensions

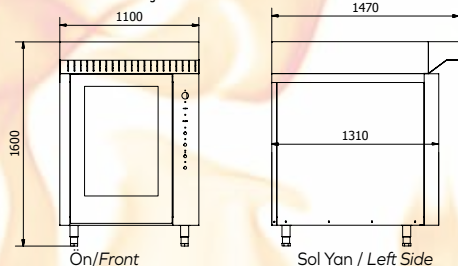

Taşıma Standı / Oven Stand

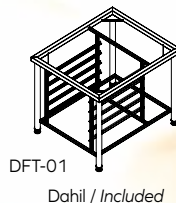

Opsiyonel Parçalar / Optional Parts

600 x 400 mm Tepsi Rafı /
600 x 400 mm Tray Shelf



Mayalama ve Saklama Dolabı /
Fermentation Cabinet

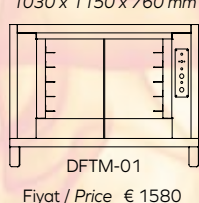

MD-08

1580 €

Mayalama ve Saklama Dolabı
Fermentation Cabinet



600 x 400 mm x 8 tepsi
kapasiteli

600 x 400 mm x 8 trays
capacity



Aydınlatma lambalı pişirme kabini
Cooking cabinet with lighting lamp



Manuel su haznesi
Manual water tank



Paslanmaz çelik gövde ve şase
Stainless steel chassis construction



Sağlamlaştırılmış şase
Hardened chassis



Kullanıcı dostu kumanda ara yüzü
User-friendly control interface

Genel Özellikler

- Paslanmaz çelik gövde ve şase
- Termostatik kontrol
- Temizlik kolaylığı sunan kabin tasarımı
- Kullanıcı dostu kumanda ara yüzü
- Aydınlatma lambalı pişirme kabini
- MKF-4, MKF-4P, MKF-6, MKF-6G, MKF-10 ve MKF-10 G ile uyumludur
- Manuel su haznesi

General Features

- Stainless steel chasis construction
- Thermostatically controlled
- Interior design provides ease of cleaning
- User-friendly command interface
- Cooking cabinet with lighting lamb
- Compatible with MKF-4, MKF-4P, MKF-6, MKF-6G, MKF-10 and MKF-10G
- Manual water tank

TEKNİK ÖZELLİKLER / TECHNICAL SPECIFICATIONS

Model / Model	MD-08
Güç girişi / Power input	200V /3/N ~ 50Hz
Güç kaynağı / Power supply	Electric
Kablo kesiti mm ² / Cable Cross mm ²	3 x 2,5
Kumanda tipi / Command type	Analog
Raf tipi (mm) / Shelve type (mm)	600 x 400
Raf kapasitesi (ad) / Shelve capacity (qty)	8
Termometre (°C) / Thermometer (°C)	0-90
İç ölçüler (WxDxH) (mm) / Internal dimensions (WxDxH) (mm)	620 x 570 x 590
Dış ölçüler (WxDxH) (mm) / External dimensions (WxDxH) (mm)	930 x 760 x 850
Net ağırlık (kg) / Net weight (kg)	63
Brüt ağırlık (kg) / Gross weight (kg)	66

Genel Ölçüler / General Dimensions

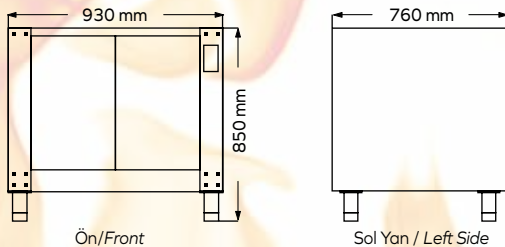

Opsiyonel Parçalar / Optional Parts

600 x 400 mm Tepsi Rafı /
600 x 400 mm Tray Shelf

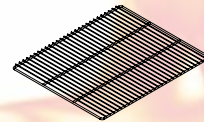

TR-02

Fiyat / Price € 28

MKF Opsiyonlar



Gastronom tepsileri
kullanmaya yönelik tepsi kiti

*Tray kit for using
gastronomy trays*

Farklı ölçüde tepsileri kullanmaya
yönelik tepsi rafı

Tray shelf to use different size trays

TR-02



28 €

600 x 400 mm

TR-03

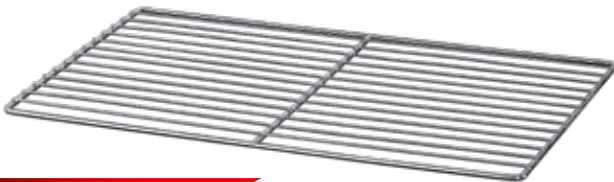

24 €

GN 1/1

TK-01

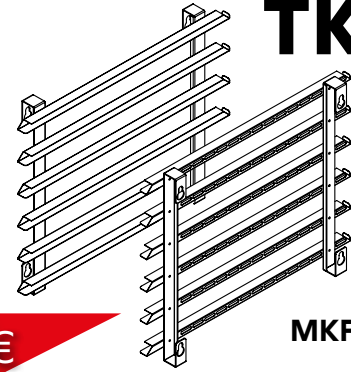

104 €

MKF-6

TK-02

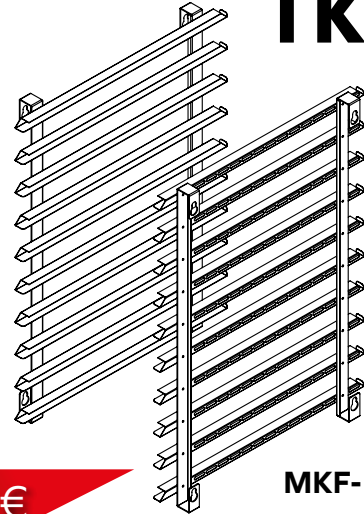

172 €

MKF-10

TK-03

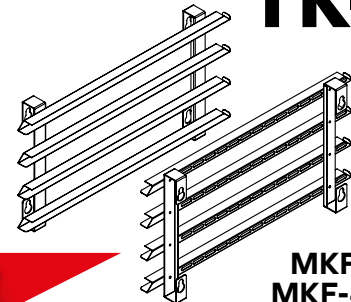

84 €

MKF-4
MKF-4P

Fırını verimli kullanılacak yüksekliğe
ulaştırın taşıma standı

*Stand that raises the oven to the height
to be used efficiently*

FT-02



480 €

MKF-6
MKF-10

FT-03



220 €

MKF-3

FT-04



300 €

MKF-4

FT-05



360 €

MKF-4P

MKF

Gastronomi
Gastronomy



MKF-20E

MKF-20G

MKF-40E

MKF-40G

MAKSAN®



MKF-40E



MKF-20E

5700 €



*Elektrik ısıtmalı Konveksiyonlu
Gastronomi Fırını,
Electric Heated Convection
Gastronomy Oven*



**Gastronom 1 / 1 x 20
tepsi kapasiteli**
**Gastronom 1 / 1 x 20
trays**



Aydınlatma lambalı pişirme kabini
Cooking cabinet with lighting lamb



Dayanıklı kapak sistemi
Durable door arm system



Paslanmaz çelik gövde ve şase
Stainless steel chassis construction



İki yönlü fan sistemi ile kusursuz pişirme
Perfect cooking with clockwise-anticlockwise fan system



Kullanıcı dostu kumanda ara yüzü
User-friendly control interface

Genel Özellikler

- Paslanmaz çelik gövde ve şase
- 10 adet GN 2/1 tepsi veya 20 adet GN 1/1 tepsi pişirme imkanı
- Yüksek verimli elektrikli ısıtma sistemi
- Kullanıcı tarafından sökülebilen çift camlı kapak sistemi ile temizlik imkanı
- Kapağın kapatılmasıyla başlayan pişirme döngüsü
- Kontrol edilebilir baca çıkışı
- Su bağlantısı ile gıdaların pişirilirken nemlendirilmesi olanağı
- Fonksiyonel otomatik nemlendirmeli pişirme programları
- Güvenliği sağlayan emniyet termostatu
- Fırın iç tasarımı ile temizlik kolaylığı
- Kullanıcı dostu kumanda ara yüzü
- Yüksekliği ayarlanabilir ayaklar
- Uluslararası güvenlik standartlarına uygunluk
- Avrupa üretimi motor ve tanlar
- İki yönlü fan sistemi ile kusursuz pişirme

General Features

- Stainless steel chasis construction
- Ability to cook 10 pieces of GN 2/1 trays or 20 pieces of GN 1/1 trays
- Highly efficient electric heating system
- Double-glazed removable door system allows to clean it by the user
- Cooking cycle start at door closing
- The flue outlet is controllable
- Water connection allows you to cooking foods with humidity
- Functional automatic cooking programs with humidification
- Safety thermostat is provided for security
- Interior design provides ease of cleaning
- User-friendly command interface
- Height adjustable feet
- Conformation to international safety standards
- Motors and fans are manufactured in EU
- Perfect cooking with clockwise-anticlockwise

TEKNİK ÖZELLİKLER / TECHNICAL SPECIFICATIONS

Model / Model	MKF-20E
Güç girişi / Power input	380V/3/N ~ 50Hz
Su girişi / Water input	3/4"
Güç kaynağı / Power supply	Electric
Kumanda tipi / Command type	Analog
Zamanlayıcı (dk.) / Timer (min.)	120
Raf tipi (mm) / Shelve type (mm)	2/1 Gastronomi
Raf kapasitesi (ad) / Shelve capacity (qty)	10
Raf aralığı (mm) / Shelf space (mm)	60
Pişirme sıcaklığı (°C) / Cooking temperature (°C)	300
Dinamik su giriş basıncı (Bar) / Dynamic water input pressure (Bar)	2-6
Dış ölçüler (WxDxH) (mm) / External dimensions (WxDxH) (mm)	950 x 1280 x 990
Fan gücü (kW) / Heating fan power (kW)	0,75
Konveksiyon gücü (kW) / Convection power (kW)	15
Toplam güç (kW) / Total power (kW)	16
Kablo kesiti (mm ²) / Cable cross-section (mm ²)	5x4
Net ağırlık (kg) / Net weight (kg)	171
Brüt ağırlık (kg) / Gross weight (kg)	188

Genel Ölçüler / General Dimensions

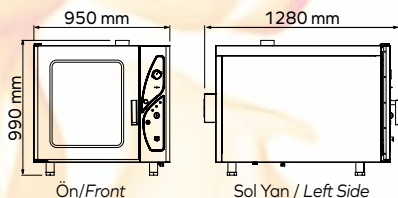

Opsiyonel Parçalar / Optional Parts

Taşıma Standı /
Oven Stand

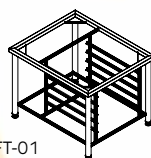

Fiyat / Price € 570

GN 2/1 Tepsi Kiti /
GN 2/1 Tray Kit

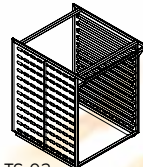

Fiyat / Price € 520

GN 2/1 Tepsi Taşıma arabası /
GN 2/1 Roll in-Rock

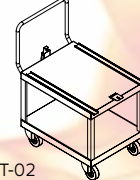

Fiyat / Price € 700

GN 2/1 Tepsi Rafi /
GN 2/1 Tray Shelf

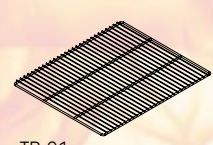

Fiyat / Price € 22

MKF-20G

6260 €



*Gaz ısıtmalı Konveksiyonlu
Gastronomi Fırını,
Gas Heated Convection
Gastronomy Oven*



**Gastronom 1 / 1 x 20
tepsi kapasiteli**
**Gastronom 1 / 1 x 20
trays**



Aydınlatma lambalı pişirme kabini
Cooking cabinet with lighting lamb



Dayanıklı kapak sistemi
Durable door arm system



Paslanmaz çelik gövde ve şase
Stainless steel chasis construction



Avrupa Üretim Motor ve Fanlar
Motor and Fans are manufactured in EU



Kullanıcı dostu kumanda ara yüzü
User-friendly control interface

Genel Özellikler

- Paslanmaz çelik gövde ve şase
- 10 adet GN 2/1 tepsi veya 20 adet GN 1/1 tepsi pişirme imkanı
- Yüksek verimli gaz ısıtma sistemi
- Kullanıcı tarafından sökülebilen çift camlı kapak sistemi ile temizlik imkanı
- Kapağın kapatılmasıyla başlayan pişirme döngüsü
- Su bağlantısı ile gıdaların pişirilirken nemlendirilmesi olanağı
- Fonsiyonel otomatik nemlendirmeli pişirme programları
- Güvenliği sağlayan emniyet termostatu
- Fırın iç tasarımı ile temizlik kolaylığı
- Kullanıcı dostu kumanda ara yüzü
- Yüksekliği ayarlanabilir ayaklar
- Uluslararası güvenlik standartlarına uygunluk
- Avrupa üretimi motor ve fanlar
- İsteğe bağlı NG veya LPG'ye uyumlu üretim

General Features

- Stainless steel chasis construction
- Ability to cook 10 pieces of GN 2/1 trays or 20 pieces of GN 1/1 trays
- Highly efficient gas heating system
- Double-glazed removable door system allows to clean it by the user
- Cooking cycle start at door closing
- Water connection allows you to cooking foods with humidity
- Functional automatic cooking programs with humidification
- Safety thermostat is provided for security
- Interior design provides ease of cleaning
- User-friendly command interface
- Height adjustable feet
- Conformation to international safety standards
- Motors and fans are manufactured in EU
- Production compatible with NG or LPG upon request

TEKNİK ÖZELLİKLER / TECHNICAL SPECIFICATIONS

Model / Model	MKF-20G
Güç girişi / Power input	380V/3/N ~ 50Hz
Su girişi / Water input	3/4"
Güç kaynağı / Power supply	Gas
Gaz girişi / Gas input	1/2"
Kumanda tipi / Command type	Analog
Zamanlayıcı (dk.) / Timer (min.)	120
Raf tipi (mm) / Shelve type (mm)	2/1 Gastronomi
Raf kapasitesi (ad) / Shelve capacity (qty)	10
Raf aralığı (mm) / Shelf space (mm)	60
Pişirme sıcaklığı (°C) / Cooking temperature (°C)	300
Dinamik su giriş basıncı (Bar) / Dynamic water input pressure (Bar)	2-6
Dış ölçüler (WxDxH) (mm) / External dimensions (WxDxH) (mm)	950 x 1280 x 990
Fan gücü (kW) / Heating fan power (kW)	0,75
Konveksiyon gücü (kW) / Convection power (kW)	16
Toplam güç (kW) / Total power (kW)	1
Toplam gaz sarfiyatı / Total gas consumption	1.6 m3/h G20 (NG) - 1.2 kg/h G30 LPG
Kablo kesiti (mm2) / Cable cross-section (mm2)	5x2,5
Net ağırlık (kg) / Net weight (kg)	171
Brüt ağırlık (kg) / Gross weight (kg)	188

Genel Ölçüler / General Dimensions

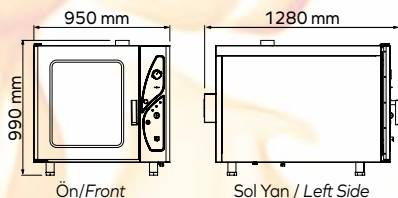

Opsiyonel Parçalar / Optional Parts

Taşıma Standı /
Oven Stand

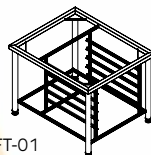

Fiyat / Price € 570

GN 2/1 Tepsi Kiti /
GN 2/1 Tray Kit

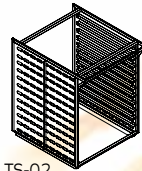

Fiyat / Price € 520

GN 2/1 Tepsi Taşıma arabası /
GN 2/1 Roll in-Rock

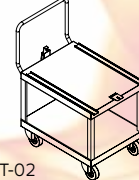

Fiyat / Price € 700

GN 2/1Tepsi Rafi /
GN 2/1Tray Shelf

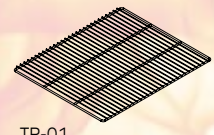

Fiyat / Price € 22

MKF-40E

8960 €



*Elektrik ısıtmalı Konveksiyonlu
Gastronomi Fırını,
Electric Heated Convection
Gastronomy Oven*



**Gastronom 1 / 1 x 40
tepsi kapasiteli**

**Gastronom 1 / 1 x 40
trays**



Aydınlatma lambalı pişirme kabini
Cooking cabinet with lighting lamp



Dayanıklı kapak sistemi
Durable door arm system



Paslanmaz çelik gövde ve şase
Stainless steel chassis construction



İki yönlü fan sistemi ile kusursuz pişirme
Perfect cooking with clockwise-anticlockwise fan system



Kullanıcı dostu kumanda ara yüzü
User-friendly control interface

Genel Özellikler

- Paslanmaz çelik gövde ve şase
- 20 adet GN 2/1 tepsi veya 40 adet GN 1/1 tepsi pişirme imkanı
- Yüksek verimli elektrikli ısıtma sistemi
- Kullanıcı tarafından sökülebilen çift camlı kapak sistemi ile temizlik imkanı
- Kapağın kapatılmasıyla başlayan pişirme döngüsü
- Kontrol edilebilir baca çıkışı
- Su bağlantısı ile gıdaların pişirilirken nemlendirilmesi olanağı
- Fonksiyonel otomatik nemlendirmeli pişirme programları
- Güvenliği sağlayan emniyet termostatu
- Fırın iç tasarımı ile temizlik kolaylığı
- Kullanıcı dostu kumanda ara yüzü
- Yüksekliği ayarlanabilir ayaklar
- Uluslararası güvenlik standartlarına uygunluk
- Avrupa üretimi motor ve tanlar
- İki yönlü fan sistemi ile kusursuz pişirme

General Features

- Stainless steel chasis construction
- Ability to cook 20 pieces of GN 2/1 trays or 40 pieces of GN 1/1 trays
- Highly efficient electric heating system
- Double-glazed removable door system allows to clean it by the user
- Cooking cycle start at door closing
- The flue outlet is controllable
- Water connection allows you to cooking foods with humidity
- Functional automatic cooking programs with humidification
- Safety thermostat is provided for security
- Interior design provides ease of cleaning
- User-friendly command interface
- Height adjustable feet
- Conformation to international safety standards
- Motors and fans are manufactured in EU
- Perfect cooking with clockwise-anticlockwise

TEKNİK ÖZELLİKLER / TECHNICAL SPECIFICATIONS

Model / Model	MKF-40E
Güç girişi / Power input	380V/3/N ~ 50Hz
Su girişi / Water input	3/4"
Güç kaynağı / Power supply	Electric
Kumanda tipi / Command type	Analog
Zamanlayıcı (dk.) / Timer (min.)	120
Raf tipi (mm) / Shelve type (mm)	2/1 Gastronomi
Raf kapasitesi (ad) / Shelve capacity (qty)	20
Raf aralığı (mm) / Shelf space (mm)	60
Pişirme sıcaklığı (°C) / Cooking temperature (°C)	300
Dinamik su giriş basıncı (Bar) / Dynamic water input pressure (Bar)	2-6
Dış ölçüler (WxDxH) (mm) / External dimensions (WxDxH) (mm)	950 x 1280 x 1800
Fan gücü (kW) / Heating fan power (kW)	1,5
Konveksiyon gücü (kW) / Convection power (kW)	30
Toplam güç (kW) / Total power (kW)	32
Kablo kesiti (mm ²) / Cable cross-section (mm ²)	5x6
Net ağırlık (kg) / Net weight (kg)	257
Brüt ağırlık (kg) / Gross weight (kg)	282

Genel Ölçüler / General Dimensions

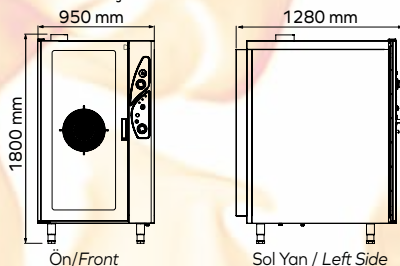

Opsiyonel Parçalar / Optional Parts



MKF-40G

9540 €



*Gaz ısıtmalı Konveksiyonlu
Gastronomi Fırını,
Gas Heated Convection
Gastronomy Oven*



**Gastronom 1 / 1 x 40
tepsi kapasiteli**

**Gastronom 1 / 1 x 40
trays**



Aydınlatma lambalı pişirme kabini
Cooking cabinet with lighting lamp



Dayanıklı kapak sistemi
Durable door arm system



Paslanmaz çelik gövde ve şase
Stainless steel chassis construction



Avrupa Üretim Motor ve Fanlar
Motor and Fans are manufactured in EU



Kullanıcı dostu kumanda ara yüzü
User-friendly control interface

Genel Özellikler

- Paslanmaz çelik gövde ve şase
- 20 adet GN 2/1 tepsi veya 40 adet GN 1/1 tepsi pişirme imkanı
- Yüksek verimli gaz ısıtma sistemi
- Kullanıcı tarafından sökülebilen çift camlı kapak sistemi ile temizlik imkanı
- Kapağın kapatılmasıyla başlayan pişirme döngüsü
- Su bağlantısı ile gıdaların pişirilirken nemlendirilmesi olanağı
- Fonsiyonel otomatik nemlendirmeli pişirme programları
- Güvenliği sağlayan emniyet termostati
- Fırın iç tasarımı ile temizlik kolaylığı
- Kullanıcı dostu kumanda ara yüzü
- Yüksekliği ayarlanabilir ayaklar
- Uluslararası güvenlik standartlarına uygunluk
- Avrupa üretimi motor ve fanlar
- İsteğe bağlı NG veya LPG'ye uyumlu üretim

General Features

- Stainless steel chasis construction
- Ability to cook 20 pieces of GN 2/1 trays or 40 pieces of GN 1/1 trays
- Highly efficient gas heating system
- Double-glazed removable door system allows to clean it by the user
- Cooking cycle start at door closing
- Water connection allows you to cooking foods with humidity
- Functional automatic cooking programs with humidification
- Safety thermostat is provided for security
- Interior design provides ease of cleaning
- User-friendly command interface
- Height adjustable feet
- Conformation to international safety standards
- Motors and fans are manufactured in EU
- Production compatible with NG or LPG upon request

TEKNİK ÖZELLİKLER / TECHNICAL SPECIFICATIONS

Model / Model	MKF-40G
Güç girişi / Power input	380V/3/N ~ 50Hz
Su girişi / Water input	3/4"
Güç kaynağı / Power supply	Gas
Gaz girişi / Gas input	1/2"
Kumanda tipi / Command type	Analog
Zamanlayıcı (dk.) / Timer (min.)	120
Raf tipi (mm) / Shelve type (mm)	2/1 Gastronomi
Raf kapasitesi (ad) / Shelve capacity (qty)	20
Raf aralığı (mm) / Shelf space (mm)	60
Pişirme sıcaklığı (°C) / Cooking temperature (°C)	300
Dinamik su giriş basıncı (Bar) / Dynamic water input pressure (Bar)	2-6
Dış ölçüler (WxDxH) (mm) / External dimensions (WxDxH) (mm)	950 x 1280 x 1800
Fan gücü (kW) / Heating fan power (kW)	1,5
Konveksiyon gücü (kW) / Convection power (kW)	32
Toplam güç (kW) / Total power (kW)	1,75
Toplam gaz sarfiyatı / Total gas consumption	3.2 m3/h G20 (NG) - 2.4 kg/h G30 LPG
Kablo kesiti (mm2) / Cable cross-section (mm2)	5x2,5
Net ağırlık (kg) / Net weight (kg)	257
Brüt ağırlık (kg) / Gross weight (kg)	282

Genel Ölçüler / General Dimensions

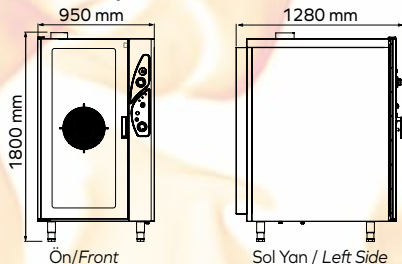

Opsiyonel Parçalar / Optional Parts

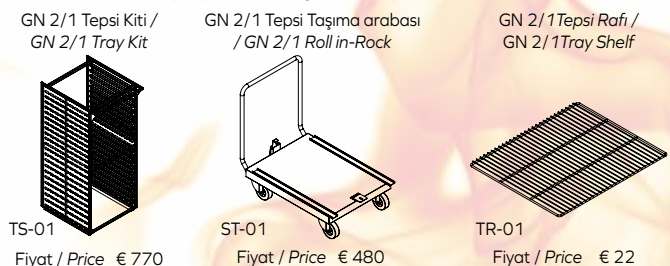

MKF

Gastronomi Opsiyonlar



CE





FT-01

MKF-20E
MKF-20G

570 €



TS-02

MKF-20E
MKF-20G

520 €



ST-02

MKF-20E
MKF-20G

700 €

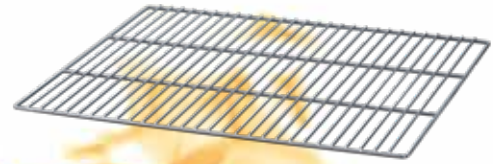

TR-01

GN 2/1

22 €



TS-01

MKF-40E
MKF-40G

770 €



ST-01

MKF-40E
MKF-40G

480 €



Pizza Fırınları

Pizza Ovens

PO-401



PO-402

PO-501



PO-502

PO-601



PO-602

PO-901



PO-902

MAKSAN®



PO-401



Tek Katlı Pizza Fırınları
Single Deck Pizza Oven



Ø 25 cm x 4 pizza
tepsi kapasiteli

Ø 25 cm x 4 pizza
tray capacity



PO-401 860 €

Genel Özellikler

- Pencereli fırın kapağı
- Kolay kullanıma sahip kumanda paneli
- Termostat kontrollü (0-400 °C).
- Özel izolasyonlu fırın bloğu
- Kolay ve pratik temizlik imkanı
- Tezgah üstünde kullanıma uygun dizayn
- Özel ateş tuğlasından yapılmış fırın zemini
- Aydınlatma lambalı pişirme kabini



PO-401T 956 €

Analog termometre göstergeli
With analogic thermometer gauge

General Features

- The oven door with window
- Easy to use command panel
- Thermostat-controlled (0-400 °C)
- Special isolated oven block
- Easy to clean and practical.
- The oven design for use over the counter.
- The cooking base is made of fire brick
- Cooking cabinet with lighting lamp

Opsiyonel Parçalar /
Optional Parts

FT-04 Taşıma Standı /
FT-04 Oven Stand
Fiyat / Price € 300

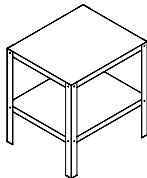

Genel Ölçüler / General Dimensions

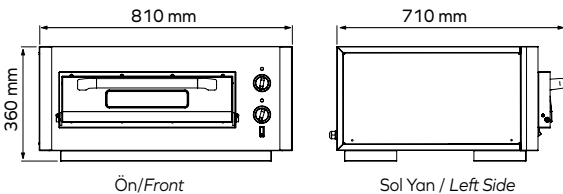

Ön/Front

Sol Yan / Left Side

TEKNİK ÖZELLİKLER / TECHNICAL SPECIFICATIONS

Model / Model	PO-401 / 401T
Güç girişi / Power input	220V/1/N ~ 50Hz
Güç kaynağı / Power supply	Electric
Kapasite / Capacity	Ø 25 cm x 4
Kumanda tipi / Command type	Analog
Pişirme sıcaklığı (°C) / Cooking temperature (°C)	400
İç ölçüler (WxDxH) (mm) / Internal dimensions (WxDxH) (mm)	510 x 510 x 100
Dış ölçüler (WxDxH) (mm) / External dimensions (WxDxH) (mm)	810 x 710 x 360
Toplam güç (kW) / Total power (kW)	4
Net ağırlık (kg) / Net weight (kg)	55
Brüt ağırlık (kg) / Gross weight (kg)	60



PO-402

Çift Katlı Pizza Fırınları
Double Deck Pizza Oven

Ø 25 cm x 8 pizza
tepsi kapasiteli

Ø 25 cm x 8 pizza
tray capacity



Genel Özellikler

- Pencereli fırın kapağı
- Kolay kullanıma sahip kumanda paneli
- Termostat kontrollü (0-400 °C).
- Özel izolasyonlu fırın bloğu
- Kolay ve pratik temizlik imkanı
- Tezgah üstünde kullanıma uygun dizayn
- Özel ateş tuğlasından yapılmış fırın zemini
- Aydınlatma lambalı pişirme kabini

General Features

- The oven door with window
- Easy to use command panel
- Thermostat-controlled (0-400 °C)
- Special isolated oven block
- Easy to clean and practical.
- The oven design for use over the counter.
- The cooking base is made of fire brick
- Cooking cabinet with lighting lamp



PO-402 1220 €



PO-402T 1384 €

Analog termometre göstergeli
With analogic thermometer gauge

TEKNİK ÖZELLİKLER / TECHNICAL SPECIFICATIONS

Model / Model	PO-402 / 402T
Güç girişi / Power input	*380V/3/N ~ 50Hz
Güç kaynağı / Power supply	Electric
Kapasite / Capacity	Ø 25 cm x 8
Kumanda tipi / Command type	Analog
Pişirme sıcaklığı (°C) / Cooking temperature (°C)	400
İç ölçüler (WxDxH) (mm) / Internal dimensions (WxDxH) (mm)	510 x 510 x 100
Dış ölçüler (WxDxH) (mm) / External dimensions (WxDxH) (mm)	780 x 710 x 530
Toplam güç (kW) / Total power (kW)	6
Net ağırlık (kg) / Net weight (kg)	80
Brüt ağırlık (kg) / Gross weight (kg)	85

*İsteğe bağlı / Upon request 220V / 1/N

Opsiyonel Parçalar /
Optional Parts

FT-04 Taşıma Standı /
FT-04 Oven Stand
Fiyat / Price € 300

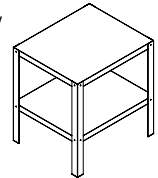

Genel Ölçüler / General Dimensions

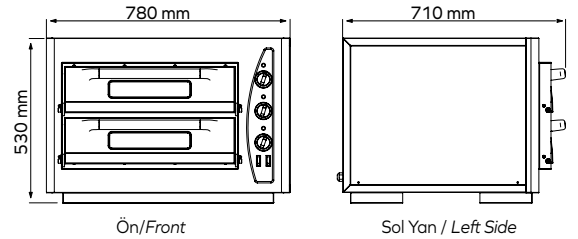

Ön/Front

Sol Yan / Left Side

PO-501



Tek Katlı Pizza Fırınları
Single Deck Pizza Oven



Ø 30 cm x 4 pizza
tepsi kapasiteli

Ø 30 cm x 4 pizza
tray capacity



PO-501 1080 €

Genel Özellikler

- Pencereli fırın kapağı
- Kolay kullanıma sahip kumanda paneli
- Termostat kontrollü (0-400 °C).
- Özel izolasyonlu fırın bloğu
- Kolay ve pratik temizlik imkanı
- Tezgah üstünde kullanıma uygun dizayn
- Özel ateş tuğlasından yapılmış fırın zemini
- Aydınlatma lambalı pişirme kabini



PO-501T 1176 €

Analog termometre göstergeli
With analogic thermometer gauge

General Features

- The oven door with window
- Easy to use command panel
- Thermostat-controlled (0-400 °C)
- Special isolated oven block
- Easy to clean and practical.
- The oven design for use over the counter.
- The cooking base is made of fire brick
- Cooking cabinet with lighting lamp

Opsiyonel Parçalar /
Optional Parts

FT-05 Taşıma Standı /
FT-05 Oven Stand
Fiyat / Price € 360

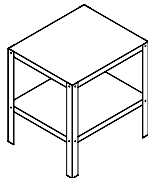

Genel Ölçüler / General Dimensions

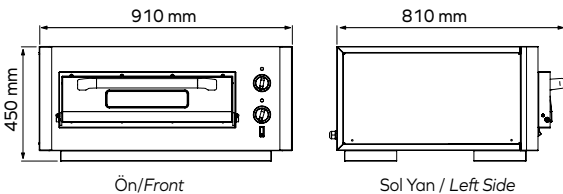

Ön/Front

Sol Yan / Left Side

TEKNİK ÖZELLİKLER / TECHNICAL SPECIFICATIONS

Model / Model	PO-501 / 501T
Güç girişi / Power input	*380V/3/N ~ 50Hz
Güç kaynağı / Power supply	Electric
Kapasite / Capacity	Ø 30 cm x 4
Kumanda tipi / Command type	Analog
Pişirme sıcaklığı (°C) / Cooking temperature (°C)	400
İç ölçüler (WxDxH) (mm) / Internal dimensions (WxDxH) (mm)	615 x 615 x 150
Dış ölçüler (WxDxH) (mm) / External dimensions (WxDxH) (mm)	910 x 810 x 450
Toplam güç (kW) / Total power (kW)	5
Net ağırlık (kg) / Net weight (kg)	80
Brüt ağırlık (kg) / Gross weight (kg)	86

*İsteğe bağlı / Upon request 220V /1/N



PO-502

Çift Katlı Pizza Fırınları
Double Deck Pizza Oven



Ø 30 cm x 8 pizza
tepsi kapasiteli

Ø 30 cm x 8 pizza
tray capacity

Genel Özellikler

- Pencereli fırın kapağı
- Kolay kullanıma sahip kumanda paneli
- Termostat kontrollü (0-400 °C).
- Özel izolasyonlu fırın bloğu
- Kolay ve pratik temizlik imkanı
- Tezgah üstünde kullanıma uygun dizayn
- Özel ateş tuğlasından yapılmış fırın zemini
- Aydınlatma lambalı pişirme kabini

General Features

- The oven door with window
- Easy to use command panel
- Thermostat-controlled (0-400 °C)
- Special isolated oven block
- Easy to clean and practical.
- The oven design for use over the counter.
- The cooking base is made of fire brick
- Cooking cabinet with lighting lamp



PO-502 1820 €



PO-502T 2010 €

Analog termometre göstergeli
With analogic thermometer gauge

TEKNİK ÖZELLİKLER / TECHNICAL SPECIFICATIONS

Model / Model	PO-502 / 502T
Güç girişi / Power input	*380V/3/N ~ 50Hz
Güç kaynağı / Power supply	Electric
Kapasite / Capacity	Ø 30 cm x 8
Kumanda tipi / Command type	Analog
Pişirme sıcaklığı (°C) / Cooking temperature (°C)	400
İç ölçüler (WxDxH) (mm) / Internal dimensions (WxDxH) (mm)	615 x 615 x 150
Dış ölçüler (WxDxH) (mm) / External dimensions (WxDxH) (mm)	910 x 810 x 780
Toplam güç (kW) / Total power (kW)	10
Net ağırlık (kg) / Net weight (kg)	135
Brüt ağırlık (kg) / Gross weight (kg)	140

*İsteğe bağlı / Upon request 220V / 1/N

Opsiyonel Parçalar /
Optional Parts

FT-05 Taşıma Standı /
FT-05 Oven Stand
Fiyat / Price € 360

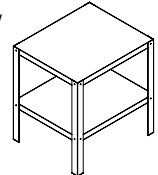

Genel Ölçüler / General Dimensions

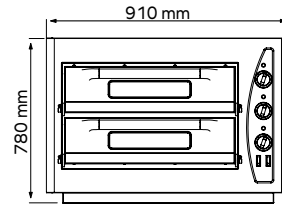

Ön/Front

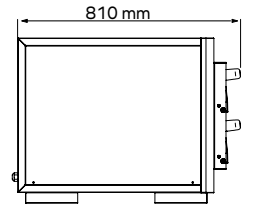

Sol Yan / Left Side

PO-601



Tek Katlı Pizza Fırınları
Single Deck Pizza Oven



Ø 30 cm x 6 pizza
tepsi kapasiteli

Ø 30 cm x 6 pizza
tray capacity



PO-601 1300 €

Genel Özellikler

- Pencereli fırın kapağı
- Kolay kullanıma sahip kumanda paneli
- Termostat kontrollü (0-400 °C).
- Özel izolasyonlu fırın bloğu
- Kolay ve pratik temizlik imkanı
- Tezgah üstünde kullanıma uygun dizayn
- Özel ateş tuğlasından yapılmış fırın zemini
- Aydınlatma lambalı pişirme kabini



PO-601T 1396 €

Analog termometre göstergeli
With analogic thermometer gauge

General Features

- The oven door with window
- Easy to use command panel
- Thermostat-controlled (0-400 °C)
- Special isolated oven block
- Easy to clean and practical.
- The oven design for use over the counter.
- The cooking base is made of fire brick
- Cooking cabinet with lighting lamp

Opsiyonel Parçalar /
Optional Parts

FT-06 Taşıma Standı /
FT-06 Oven Stand
Fiyat / Price € 380

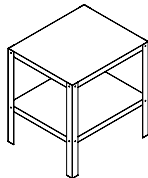

Genel Ölçüler / General Dimensions

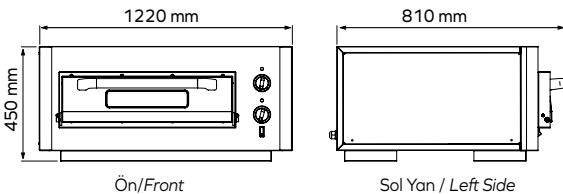

Ön/Front

Sol Yan / Left Side

TEKNİK ÖZELLİKLER / TECHNICAL SPECIFICATIONS

Model / Model	PO-601 / 601T
Güç girişi / Power input	*380V/3/N ~ 50Hz
Güç kaynağı / Power supply	Electric
Kapasite / Capacity	Ø 30 cm x 6
Kumanda tipi / Command type	Analog
Pişirme sıcaklığı (°C) / Cooking temperature (°C)	400
İç ölçüler (WxDxH) (mm) / Internal dimensions (WxDxH) (mm)	920 x 615 x 150
Dış ölçüler (WxDxH) (mm) / External dimensions (WxDxH) (mm)	1220 x 810 x 450
Toplam güç (kW) / Total power (kW)	6
Net ağırlık (kg) / Net weight (kg)	100
Brüt ağırlık (kg) / Gross weight (kg)	110

*İsteğe bağlı / Upon request 220V /1/N



PO-602

Çift Katlı Pizza Fırınları
Double Deck Pizza Oven

Ø 30 cm x 12 pizza
tepsi kapasiteli

Ø 30 cm x 12 pizza
tray capacity



Genel Özellikler

- Pencereli fırın kapağı
- Kolay kullanıma sahip kumanda paneli
- Termostat kontrollü (0-400 °C).
- Özel izolasyonlu fırın bloğu
- Kolay ve pratik temizlik imkanı
- Tezgah üstünde kullanıma uygun dizayn
- Özel ateş tuğlasından yapılmış fırın zemini
- Aydınlatma lambalı pişirme kabini

General Features

- The oven door with window
- Easy to use command panel
- Thermostat-controlled (0-400 °C)
- Special isolated oven block
- Easy to clean and practical.
- The oven design for use over the counter.
- The cooking base is made of fire brick
- Cooking cabinet with lighting lamp



PO-602

2400 €



PO-602T

Analog termometre göstergeli
With analogic thermometer gauge

2590 €

TEKNİK ÖZELLİKLER / TECHNICAL SPECIFICATIONS

Model / Model	PO-602 / 602T
Güç girişi / Power input	380V/3/N ~ 50Hz
Güç kaynağı / Power supply	Electric
Kapasite / Capacity	Ø 30 cm x 12
Kumanda tipi / Command type	Analog
Pişirme sıcaklığı (°C) / Cooking temperature (°C)	400
İç ölçüler (WxDxH) (mm) / Internal dimensions (WxDxH) (mm)	920 x 615 x 150
Dış ölçüler (WxDxH) (mm) / External dimensions (WxDxH) (mm)	1220 x 810 x 770
Toplam güç (kW) / Total power (kW)	12
Net ağırlık (kg) / Net weight (kg)	170
Brüt ağırlık (kg) / Gross weight (kg)	180

Opsiyonel Parçalar /
Optional Parts

FT-06 Taşıma Standı /
FT-06 Oven Stand
Fiyat / Price € 380

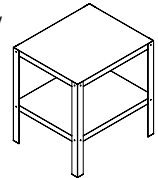

Genel Ölçüler / General Dimensions

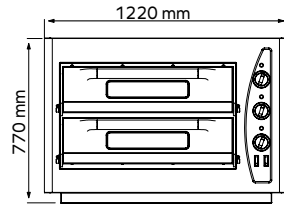

Ön/Front

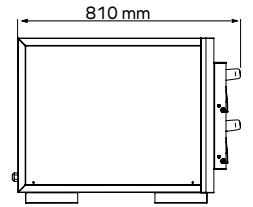

Sol Yan / Left Side

PO-901



Tek Katlı Pizza Fırınları
Single Deck Pizza Oven



Ø 30 cm x 9 pizza
tepsi kapasiteli

Ø 30 cm x 9 pizza
tray capacity



PO-901 2085 €

Genel Özellikler

- Pencereli fırın kapağı
- Kolay kullanıma sahip kumanda paneli
- Termostat kontrollü (0-400 °C).
- Özel izolasyonlu fırın bloğu
- Kolay ve pratik temizlik imkanı
- Tezgah üstünde kullanıma uygun dizayn
- Özel ateş tuğlasından yapılmış fırın zemini
- Aydınlatma lambalı pişirme kabini

General Features

- The oven door with window
- Easy to use command panel
- Thermostat-controlled (0-400 °C)
- Special isolated oven block
- Easy to clean and practical.
- The oven design for use over the counter.
- The cooking base is made of fire brick
- Cooking cabinet with lighting lamp



PO-901T 2181 €

Analog termometre göstergeli
With analogic thermometer gauge

Opsiyonel Parçalar /
Optional Parts

FT-09 Taşıma Standı /
FT-09 Oven Stand
Fiyat / Price € 460

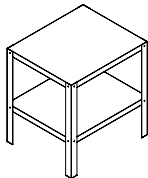

Genel Ölçüler / General Dimensions

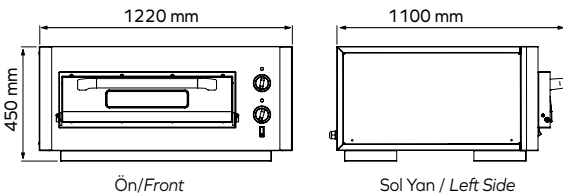

Ön/Front

Sol Yan / Left Side

TEKNİK ÖZELLİKLER / TECHNICAL SPECIFICATIONS

Model / Model	PO-901 / 901T
Güç girişi / Power input	380V/3/N ~ 50Hz
Güç kaynağı / Power supply	Electric
Kapasite / Capacity	Ø 30 cm x 9
Kumanda tipi / Command type	Analog
Pişirme sıcaklığı (°C) / Cooking temperature (°C)	400
İç ölçüler (WxDxH) (mm) / Internal dimensions (WxDxH) (mm)	920 x 920 x 150
Dış ölçüler (WxDxH) (mm) / External dimensions (WxDxH) (mm)	1220 x 1100 x 450
Toplam güç (kW) / Total power (kW)	8
Net ağırlık (kg) / Net weight (kg)	133
Brüt ağırlık (kg) / Gross weight (kg)	145



PO-902

Çift Katlı Pizza Fırınları
Double Deck Pizza Oven

Ø 30 cm x 18 pizza
tepsi kapasiteli

Ø 30 cm x 18 pizza
tray capacity



Genel Özellikler

- Pencereli fırın kapağı
- Kolay kullanıma sahip kumanda paneli
- Termostat kontrollü (0-400 °C).
- Özel izolasyonlu fırın bloğu
- Kolay ve pratik temizlik imkanı
- Tezgah üstünde kullanıma uygun dizayn
- Özel ateş tuğlasından yapılmış fırın zemini
- Aydınlatma lambalı pişirme kabini

General Features

- The oven door with window
- Easy to use command panel
- Thermostat-controlled (0-400 °C)
- Special isolated oven block
- Easy to clean and practical.
- The oven design for use over the counter.
- The cooking base is made of fire brick
- Cooking cabinet with lighting lamp



PO-902 3320 €



PO-902T 3510 €

Analog termometre göstergeli
With analogic thermometer gauge

TEKNİK ÖZELLİKLER / TECHNICAL SPECIFICATIONS

Model / Model	PO-902 / 902T
Güç girişi / Power input	380V/3/N ~ 50Hz
Güç kaynağı / Power supply	Electric
Kapasite / Capacity	Ø 30 cm x 18
Kumanda tipi / Command type	Analog
Pişirme sıcaklığı (°C) / Cooking temperature (°C)	400
İç ölçüler (WxDxH) (mm) / Internal dimensions (WxDxH) (mm)	920 x 920 x 150
Dış ölçüler (WxDxH) (mm) / External dimensions (WxDxH) (mm)	1220 x 1100 x 770
Toplam güç (kW) / Total power (kW)	16
Net ağırlık (kg) / Net weight (kg)	220
Brüt ağırlık (kg) / Gross weight (kg)	235

Opsiyonel Parçalar /
Optional Parts

FT-09 Taşıma Standı /
FT-09 Oven Stand
Fiyat / Price € 460

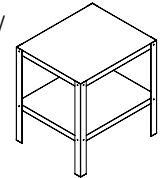

Genel Ölçüler / General Dimensions

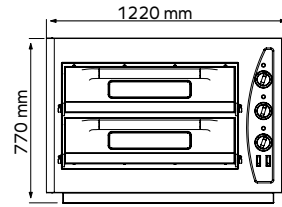

Ön/Front

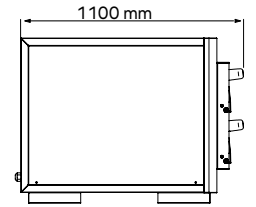

Sol Yan / Left Side

PO serisi Opsiyonlar

CE



Fırını verimli kullanılacak
yükseklğe ulařtıran
tařıma standı

FT-04



PO-401
PO-402

300 €

FT-05



PO-501
PO-502

360 €



*Stand that raises the oven
to the height to be used
efficiently*



FT-06



PO-601
PO-602

380 €

FT-09



PO-901
PO-902

460 €

Washing

Bulaşık Yıkama, Bardak Yıkama ve Sebze Yıkama Makineleri ve Aksesuarları
Dishwasher, Glasswasher, Vegetable Washer Machines and Accessories



Ürün Kodu / Product Code	Ürün / Product	Fiyat / Price
GW-535 ECO	350 x 350 mm bardak yıkama makinesi / 350 x 350 mm glasswasher	1.620 €
GW-640 ECO	400 x 400 mm bardak yıkama makinesi / 400 x 400 mm glasswasher	1.720 €
DW-500 ECO	500 x 500 mm set altı bulaşık yıkama makinesi / 500 x 500 mm undercounter dishwasher	1.900 €
DW-1000 ECO	Giyotin tip bulaşık yıkama makinesi / Pass through hood type dishwasher	2.520 €
GW-535	350 x 350 mm bardak yıkama makinesi / 350 x 350 mm glasswasher	1.740 €
GW 640	400 x 400 mm bardak yıkama makinesi / 400 x 400 mm glasswasher	1.840 €
DW-500	500 x 500 mm set altı bulaşık yıkama makinesi / 500 x 500 mm undercounter dishwasher	2.060 €
DW-1000	Giyotin tip bulaşık yıkama makinesi / Pass through hood type dishwasher	2.860 €
DW-2000	Konveyörlü tip bulaşık yıkama makinesi 2000 tb/s / Conveyor type dishwasher 2000 d/h	10.700 €
DW-3000	Konveyörlü tip bulaşık yıkama makinesi 3000 tb/s / Conveyor type dishwasher 3000 d/h	11.550 €
DW-4500	Konveyörlü tip bulaşık yıkama makinesi 4500 tb/s / Conveyor type dishwasher 4500 d/h	17.600 €
DW-6000	Konveyörlü tip bulaşık yıkama makinesi 6000 tb/s / Conveyor type dishwasher 6000 d/h	22.500 €
BS-350	GW-535 Sepet standı / Basket stand	240 €
BS-400	GW-640 Sepet standı / Basket stand	240 €
BS-500	DW-500 Sepet standı / Basket stand	240 €
DRENAJ POMPASI / DRAIN PUMP	GW-535/640, DW-500/1000 için opsiyonel / optional	112 €
DETERJAN POMPASI / DETERGENT PUMP	GW-535/640, DW-500 için opsiyonel / optional	140 €
PARLATICI POMPASI / RINSE AID PUMP	GW-535/640, DW-500 için opsiyonel / optional	140 €
DETERJAN POMPASI / DETERGENT PUMP	DW-1000/2000/3000/4500/6000 için opsiyonel / optional	160 €
PARLATICI POMPASI / RINSE AID PUMP	DW-1000/2000/3000/4500/6000 için opsiyonel / optional	160 €
ÇİFT HIZ KONV.ve SICAKLIK GÖST./DOUBLE SPEED CONV. THEM. DISP.	DW-2000/3000/4500/6000 için opsiyonel / optional	340 €
SBY-300	Sebze yıkama makinesi 300 kg/s / Continuous vegetable washer machine 300 kg/h	19.000 €
SBY-600	Sebze yıkama makinesi 600 kg/s / Continuous vegetable washer machine 600 kg/h	22.500 €
SGT-01	Sebze yıkama makinesi giriş tezgahı / Continuous vegetable washer machine entering table	870 €
SCT-01	Sebze yıkama makinesi çıkış tezgahı / Continuous vegetable washer machine exiting table	645 €

MKF Patisserie

Konveksiyonlu Patiseri Fırını
Convection Bakery Oven



Ürün Kodu / Product Code	Ürün / Product	Fiyat / Price
MKF-3	3 tepsili konveksiyonel fırın / 3 trays convection oven	1.260 €
MKF-4	4 tepsili konveksiyonel fırın / 4 trays convection oven	1.830 €
NEMLENDİRME	MKF-3 ve MKF-4 için opsiyonel nemlendirme / optional moistening	60 €
MKF-4P	4 tepsili konveksiyonel fırın / 4 trays convection oven	1.950 €
MKF-6	6 tepsili konveksiyonel fırın / 6 trays convection oven	3.550 €
MKF-10	10 tepsili konveksiyonel fırın / 10 trays convection oven	4.750 €
MKF-4P DIGI	4 tepsili dijital konveksiyonel fırın / 4 trays digital convection oven	2.590 €
MKF-6 DIGI	6 tepsili dijital konveksiyonel fırın / 6 trays digital convection oven	4.190 €
MKF-10 DIGI	10 tepsili dijital konveksiyonel fırın / 10 trays digital convection oven	5.390 €
MKF-6G	6 tepsili gazlı konveksiyonel fırın / 6 trays digital convection oven	4.020 €
MKF-10G	10 tepsili gazlı konveksiyonel fırın / 10 trays digital convection oven	5.240 €
MKDF-10	10 tepsili dönerli konveksiyonlu fırın / 10 trays rotary convection oven	11.000 €
MD-08	Mayalama dolabı / Fermentation cabinet	1.580 €
FT-02	MKF-6/10 standı / Stand	480 €
FT-03	MKF-3 standı / Stand	220 €
FT-04	MKF-4 standı / Stand	300 €
FT-05	MKF-4P standı / Stand	360 €
TR-02	Tepsi rafı 600 x 400 mm	28 €
TR-03	Tepsi rafı GN 1/1 / Tray rack	24 €
TK-01	Tepsi kiti GN 1/1 MKF-6 / Tray kit	104 €
TK-02	Tepsi kiti GN 1/1 MKF-10 / Tray kit	172 €
TK-03	Tepsi kiti GN 1/1 MKF-4/4P / Tray kit	84 €

MKF Gastronomy

Konveksiyonlu Gastronomi Fırını
Convection Gastronomy Oven



Ürün Kodu / Product Code	Ürün / Product	Fiyat / Price
MKF-20E	20 tepsili konveksiyonel fırın / 20 trays convection oven	5.700 €
MKF-20G	20 tepsili konveksiyonel fırın / 20 trays convection oven	6.260 €
MKF-40E	40 tepsili konveksiyonel fırın / 40 trays convection oven	8.960 €
MKF-40G	40 tepsili konveksiyonel fırın / 40 trays convection oven	9.540 €
FT-01	MKF-20 standı / Stand	570 €
ST-01	MKF-40 stand taşıma arabası / Roll in-Rock	480 €
ST-02	MKF-20 stand taşıma arabası / Roll in-Rock	700 €
TR-01	Tepsi rafı GN2/1 / Tray rack	22 €
TS-01	Tepsi standı MKF-40 / Tray stand	770 €
TS-02	Tepsi standı MKF-20 / Tray stand	520 €

Pizza Ovens



Ürün Kodu / Product Code	Ürün / Product	Fiyat / Price
PO-401	510 x 510 mm tek katlı pizza fırını / 510 x 510 mm single deck pizza oven	860 €
PO-401T	510 x 510 mm tek katlı göstergeli pizza fırını / 510 x 510 mm single deck with thermometer gauge pizza oven	956 €
PO-402	510 x 510 mm çift katlı pizza fırını / 510 x 510 mm double deck pizza oven	1.220 €
PO-402T	510 x 510 mm çift katlı göstergeli pizza fırını / 510 x 510 mm double deck with thermometer gauge pizza oven	1.384 €
PO-501	615 x 615 mm tek katlı pizza fırını / 615 x 615 mm single deck pizza oven	1.080 €
PO-501T	615 x 615 mm tek katlı göstergeli pizza fırını / 615 x 615 mm single deck with thermometer gauge pizza oven	1.176 €
PO-502	615 x 615 mm çift katlı pizza fırını / 615 x 615 mm double deck pizza oven	1.820 €
PO-502T	615 x 615 mm çift katlı göstergeli pizza fırını / 615 x 615 mm double deck with thermometer gauge pizza oven	2.010 €
PO-601	920 x 615 mm tek katlı pizza fırını / 920 x 615 mm single deck pizza oven	1.300 €
PO-601T	920 x 615 mm tek katlı göstergeli pizza fırını / 920 x 615 mm single deck with thermometer gauge pizza oven	1.396 €
PO-602	920 x 615 mm çift katlı pizza fırını / 920 x 615 mm double deck pizza oven	2.400 €
PO-602T	920 x 615 mm çift katlı göstergeli pizza fırını / 920 x 615 mm double deck with thermometer gauge pizza oven	2.590 €
PO-901	920 x 920 mm tek katlı pizza fırını / 920 x 920 mm single deck pizza oven	2.085 €
PO-901T	920 x 920 mm tek katlı göstergeli pizza fırını / 920 x 920 mm single deck with thermometer gauge pizza oven	2.181 €
PO-902	920 x 920 mm çift katlı pizza fırını / 920 x 920 mm double deck pizza oven	3.320 €
PO-902T	920 x 920 mm çift katlı göstergeli pizza fırını / 920 x 920 mm double deck with thermometer gauge pizza oven	3.510 €
FT-04	PO-4 standı / stand	300 €
FT-05	PO-5 standı / stand	360 €
FT-06	PO-6 standı / stand	380 €
FT-09	PO-9 standı / stand	460 €



MAKSAN®
Endüstriyel Mutfak Ekipmanları

www.maksanmutfak.com.tr

Fabrika/ Factory

Fatih Mahallesi 1181 Sokak No:1
Sarnıç, Gaziemir - İZMİR / TÜRKİYE
Tel.: +90.232.254 29 17 - 254 90 17
Fax: +90.232.281 33 11
info@maksanmutfak.com.tr

Mağaza / Showroom

Oruç Reis Mah. Giy Koop. San. Sit.
14. Sk. No: 57-59 Esenler/ İSTANBUL
Tel.: +90.212.659 85 71
Fax: +90.212.659 85 72
info@maksanmutfak.com.tr



MAKSAN bu katalogda yer alan resim ve bilgilerde her türlü değişiklik yapma hakkını saklı tutar.
Bu katalogta kullanılan tüm resimlerin sahibi MAKSAN olup herhangi bir dijital veya görsel ortamda kullanılması durumunda yasal işlem hakkına sahiptir.

MAKSAN reserves the right to change all kinds of images and information contained in this catalog.
The owner of all the pictures used in this catalog is MAKSAN and any digital or visual environment use has the right to take legal action in the event



**EKMEKÇİLER
GRUP**